

462887

**Lenze**



***Drives with worm  
gearboxes 52.□□□***



# Contents

## Introducing Lenze

_____	4
-------	---

## General data

### Worm gearboxes

Possible combinations _____	5
Actual ratios _____	5
Permissible radial force output _____	6
Starting efficiency and self-locking _____	7

### AC-motors

Technical data _____	8
----------------------	---

## Worm geared motors

Contents _____	13
Product information _____	14
Technical data _____	16
Selection _____	18
Drive selection _____	19

## Worm gearboxes

Contents _____	39
Product information _____	40
Technical data _____	42
Selection _____	44
Drive selection _____	46

## Compact units

Contents _____	51
Product information _____	52
Technical data _____	54
Selection _____	59
Drive selection _____	61

## DISCO-variable speed drive

Contents _____	73
Product information _____	74
Technical data _____	76
Selection _____	80
Drive selection _____	82

## Lenze worldwide

_____	98
-------	----

## ***Introducing Lenze***

**No matter which drive solution you imagine,  
we make your dreams come true.**

According to our maxim "one stop shopping", we offer you a complete programme of electronic and mechanical drive systems which are distinguished by reliability and efficiency. Our supply range includes frequency inverters, speed controllers, servo controllers, variable speed drives and gearboxes, clutches and brakes, as well as the appropriate motors.

Lenze is thus not only the supplier for single components, but also offers solutions for complete drive systems including project planning, execution and commissioning of your applications.

Furthermore, a worldwide service and distribution network allows a qualified customer advisory service on site and a fast and extensive after sales service.

Our quality assurance system for development, production, sales and service is certified according to DIN ISO 9001. Our customers set the scale for measuring the quality of our products.

Our task is to meet your requirements. Customer orientation as a Lenze principle means the highest quality. See for yourself.

### Possible combinations motor-gearboxes

Ratio	Gearbox size															
	04			05			06			08			10		12	
	Motor frame size															
	63	71	80	71	80	80	90	80	90	100/ 112	90	100/ 112	100/ 112	132		
5	○	○	○	○	○	○	○	○	○	○		●				
7	○	○	○	○	○		○	○	○	○		●		●		
10	○	○	○	○	○	○	○	○	○	○		●	●	●		
15	○	○	○	○	○	○	○	○	○	○	●	●	●	●		
20	○	○	○	○	○	○	○	○	○	○	●	●	●	●		
30	○	○	○	○	○	○	○	○	○	○	●	●	●	●		
40	○	○	○	○	○	○	○	○	○	○	●	●	●	●		
53	○	○	○	○	○	○	○	○	○	○	●	●	●			
60	○	○	○	○	○	○	○	○	○		●	●	●			

○ Combination is possible with motors in B5 and B14 design.

● Combination is possible with motors in B5 design.

The motor – gearbox combination only shows the constructive possibilities; the power combination must be checked, if not indicated in the selection tables.

### Actual ratios

Size	04		05		06		08		10		12	
	$z_2/z_1$	$i_t$	$z_2/z_1$	$i_t$	$z_2/z_1$	$i_t$	$z_2/z_1$	$i_t$	$z_2/z_1$	$i_t$	$z_2/z_1$	$i_t$
5	29/6	4.83	29/6	4.83	29/6	4.83	30/6	5	30/6	5	29/6	4.83
7	29/4	7.25	29/4	7.25	29/4	7.25	30/4	7.5	30/4	7.5	29/4	7.25
10	40/4	10	38/4	9.5	39/4	9.75	40/4	10	40/4	10	40/4	10
13	52/4	13	53/4	13.25	51/4	12.75	53/4	13.25	52/4	13	52/4	13
15	29/2	14.5	29/2	14.5	29/2	14.5	30/2	15	30/2	15	29/2	14.5
20	40/2	20	38/2	19	39/2	19.5	40/2	20	40/2	20	40/2	20
26	52/2	26	53/2	26.5	51/2	25.5	53/2	26.5	52/2	26	52/2	26
30	29/1	29	29/1	29	29/1	29	30/1	30	30/1	30	29/1	29
40	40/1	40	38/1	38	39/1	39	40/1	40	40/1	40	40/1	40
53	52/1	52	53/1	53	51/1	51	53/1	53	52/1	52	52/1	52
60	62/1	62	62/1	62	61/1	61	62/1	62	62/1	62	62/1	62

$z_1$  = Number of starts

$z_2$  = Number of teeth of the worm wheel

$i_t$  = Ratio

# General data

## Worm gearboxes

### Permissible radial forces output

The values for the permissible radial force  $Fr$  stated in the table below refer to the middle of the output shaft.

For forces  $Fr$  not acting on the middle of the output shaft, the permissible radial force  $Fr_{perm.}$  can be calculated as follows:

$$Fr_{perm} = Fr \cdot fw$$

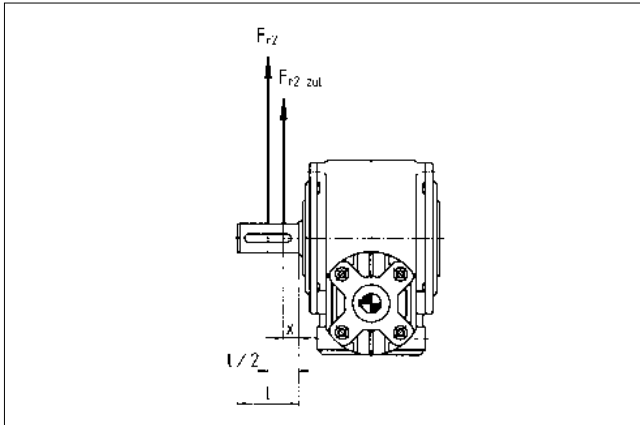

x/l	0	0,2	0,4	0,6	0,8	1
fw	1.32	1.18	1.05	0.84	0.63	0.5

Size	04	05	06	08	10	12	04	05	06	08	10	12	04	05	06	08	10	12
<b>Radial force <math>Fr_2</math> [kN]</b>																		
<b>i</b>	<b><math>n_1 = 2800</math> 1/min</b>						<b><math>n_1 = 1400</math> 1/min</b>						<b><math>n_1 = 930</math> 1/min</b>					
5	1.7	2.6	3.5	4.3	12.8	22.0	2.2	3.3	4.3	4.9	12.5	21.0	2.4	3.7	4.8	5.6	12.5	21.0
7	2.1	3.2	4.2	5.0	12.8	22.0	2.6	4.0	5.1	5.8	12.5	21.0	2.9	4.4	5.7	6.7	12.3	21.0
10	2.3	3.5	4.5	5.5	12.8	22.0	2.9	4.4	5.6	6.5	12.4	21.0	3.0	4.5	5.4	7.5	12.3	21.0
13	2.8	4.2	5.0	6.0	12.8	22.0	3.3	5.0	5.6	7.2	12.3	21.0	3.3	5.0	5.4	8.3	12.2	21.0
15	2.8	4.2	5.5	6.6	12.8	22.0	3.0	4.7	5.8	7.9	12.5	21.0	2.8	4.5	5.5	9.0	12.3	21.0
20	3.1	4.6	6.0	7.2	12.8	22.0	2.9	4.6	5.7	8.7	12.3	21.0	2.7	4.4	5.2	8.8	12.2	21.0
26	3.2	4.9	5.9	7.9	12.7	22.0	3.2	4.9	5.5	8.9	12.2	21.0	3.2	4.9	5.0	8.7	12.0	21.0
30	3.2	4.9	6.1	8.6	12.8	22.0	3.0	4.7	5.8	9.2	12.5	21.0	2.8	4.5	5.5	9.0	12.3	21.0
40	3.1	4.8	6.1	9.9	12.8	22.0	2.9	4.6	5.6	9.0	12.3	21.0	2.8	4.4	5.1	8.8	12.2	21.0
53	3.1	4.8	6.0	9.7	12.7	22.0	3.2	4.8	5.4	8.8	12.2	21.0	3.2	4.8	4.9	8.6	12.0	21.0
60	3.1	4.9	6.1	10.0	12.8	22.0	3.2	4.9	5.8	9.2	12.4	21.0	3.2	4.9	5.6	9.0	12.3	21.0
<b>i</b>	<b><math>n_1 = 700</math> 1/min</b>						<b><math>n_1 = 500</math> 1/min</b>						<b><math>n_1 = 150</math> 1/min</b>					
5	3.0	4.0	5.1	6.0	12.2	21.0	3.0	4.3	5.1	6.5	12.0	20.0	3.0	4.3	4.0	3.2	5.4	10.0
7	2.8	4.4	5.3	7.2	12.2	21.0	2.8	4.1	4.7	7.7	11.8	20.0	2.8	4.1	2.9	1.8	4.8	10.0
10	3.0	4.3	5.0	8.4	12.0	20.0	3.0	4.2	4.2	7.5	11.5	19.5	3.0	4.3	4.3	5.6	9.4	10.0
13	3.3	5.0	5.4	8.4	11.8	20.0	3.2	5.0	5.4	8.4	11.8	20.0	3.3	5.0	5.6	8.6	11.9	20.0
15	2.7	4.3	5.1	8.5	12.0	21.0	2.7	4.0	4.4	7.6	11.6	20.0	2.7	4.0	3.9	3.2	6.2	10.0
20	2.7	4.1	4.7	8.4	11.8	20.0	2.7	4.1	3.9	7.2	11.3	19.0	2.7	4.1	3.9	5.5	8.8	10.0
26	3.2	4.9	4.6	8.0	11.6	20.0	3.2	4.9	4.6	8.0	11.0	18.5	3.2	4.9	4.8	8.0	11.1	18.5
30	2.7	4.3	5.0	8.5	12.2	21.0	2.7	4.0	4.2	7.6	11.9	20.0	2.7	4.0	1.7	3.8	8.4	10.0
40	2.7	4.1	4.6	8.4	11.8	20.0	2.7	4.0	3.9	7.1	11.2	19.0	2.7	4.0	3.9	5.7	8.6	10.0
53	3.2	4.8	4.6	8.0	11.6	20.0	3.2	4.8	4.6	8.0	10.8	18.5	3.2	4.8	4.5	8.0	10.7	17.5
60	3.2	4.9	5.6	8.5	12.0	21.0	3.2	4.9	5.6	8.3	11.5	19.5	3.2	4.9	5.6	8.2	11.3	18.5

### Starting efficiency and self-locking

The efficiency of a worm gearbox is determined among others by the speed ratios in the gearing and the state of

the lubricant. In general, the efficiency increases with the gearbox size, increasing speed and decreasing ratio.

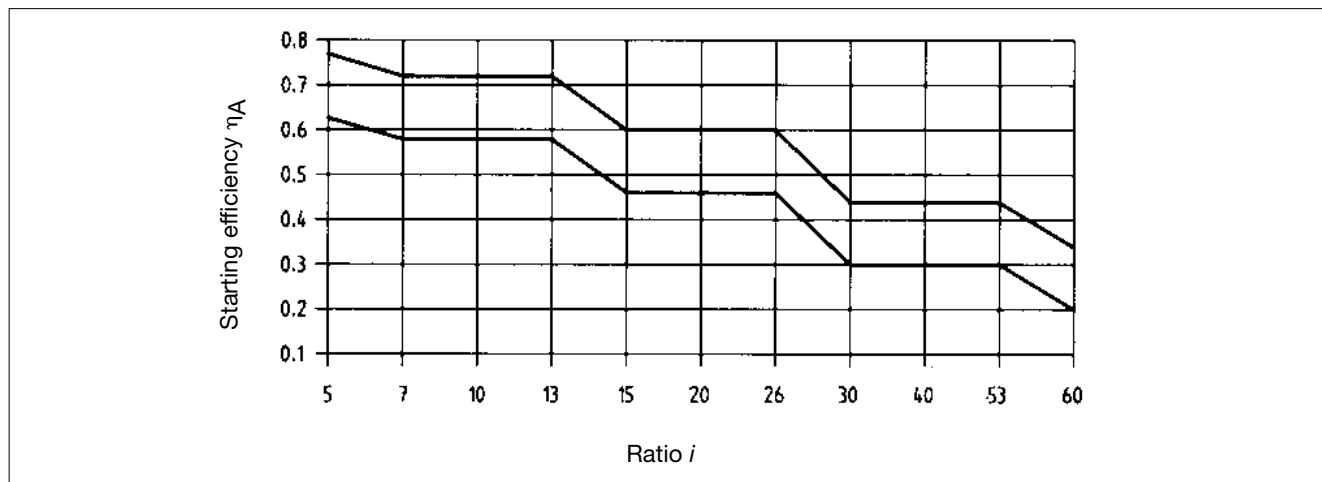

#### Starting efficiency $\eta_A$

From the above, we can conclude that the efficiency  $\eta_A$  of a worm gearbox during starting is smaller than the operating efficiency  $\eta$  at rated speed.

Therefore the starting efficiency  $\eta_A$  must always be considered when starting under load is required.

The following diagram shows the  $\eta_A$  values, which are to be expected as limit values after running in.

#### Self locking:

A worm gearbox is in a self locking or irreversibility condition when no amount of torque applied to the worm wheel will rotate the worm shaft. We distinguish between static and dynamic self locking.

#### Static self locking:

In a static self locking condition it is not possible to start the driving worm wheel from standstill. A self locking condition of the gearing can in some cases be counteracted by

shocks and/or vibrations in the gearbox so that it is possible to start driving the worm wheel!

The static self locking can be checked roughly using the above diagram and the starting efficiency  $\eta_A$ . If  $\eta_A < 0.5$ , a gearbox has static self locking.

#### Dynamic self locking:

The gearbox comes to a standstill even if a torque acts on the output side of the motor during disconnection. Dynamic self locking can be checked roughly using the total efficiency from the selection tables on pages 46/47.

If  $\eta < 0.5$ , a gearbox has dynamic self locking.

A precise check of static or dynamic self locking is possible in the factory, when the operating factors are known.

# General data

## AC-motors

### Technical data

The fitted three-phase motors comply with the standards and regulations of electrical machines IEC 34 – VDE 530 DIN 57530 and DIN 42677.

#### Voltage and frequency

Lenze supplies three-phase motors in the standard version with multiple-range voltage, in enclosure IP 55 and insulation class F, suitable for the following connecting voltages:

0.18 – 3.0 kW	(1500 1/min)	50 Hz: 220–240 / 380–415 V <sup>1)</sup>
	(1800 1/min)	60 Hz: 220–266 / 380–460 V
4.0 – 45.0 kW	(1000 1/min)	50 Hz: 220–240 / 380–415 V <sup>1)</sup>
	(1200 1/min)	60 Hz: 220–266 / 380–460 V
4.0 – 45.0 kW	(1500 1/min)	50 Hz: 380 V–415 V $\Delta^2$
	(1800 1/min)	60 Hz: 440 V–460 V $\Delta$

<sup>1)</sup> New rated voltage 230/400 V included

<sup>2)</sup> New rated voltage 400 V  $\Delta$  included

Three-phase motors with different specifications are available. Motors wound for 50 Hz can also be connected

to 60 Hz supply. The conversion factors for 60 Hz operation can be obtained from the table.

Motor winding 50 Hz	Connection to 60 Hz	Rated speed	Rated power	Rated torque
220 V	220 V	1.2	1.0	0.83
230 V	230 V	1.2	1.0	0.83
230 V	266 V	1.2	1.15	0.96
380 V	380 V	1.2	1.0	0.83
380 V	440 V	1.2	1.0	0.83
380 V	440 V	1.2	1.15	0.96
440 V	460 V	1.2	1.0	0.83
400 V	460 V	1.2	1.15	0.96
440 V	440 V	1.2	1.0	0.83
500 V	500 V	1.2	1.0	0.83
500 V	550 V	1.2	1.1	0.91

Permissible voltage tolerance  $\pm 5\%$  at rated power and rated frequency acc. to DIN 57530

#### Operating mode

Continuous operation with constant load, Operating mode S1 (VDE 0530)

#### Isolation class

Isolation class F  
Perm. continuous temperature  $\leq 155\text{ }^\circ\text{C}$

#### Enclosure

IP 55:  
Complete protection against contact, protection against dust accumulation and water jets.

#### Motor protection

We recommend to use a circuit breaker.  
Find the rated current as a first information in the table on page 9

#### Power derating

The rated power is valid for continuous operation acc. to DIN 57530, part 1, for a max. ambient temperature of  $40\text{ }^\circ\text{C}$ , and for an installation height up to 1000 m amsl.

For other conditions the permissible powers are listed in the table below.

Ambient temperature $^\circ\text{C}$	Perm. power in % of rated power
30	107
35	104
<b>40</b>	<b>100</b>
45	96
50	92
55	87
60	82

Installation height in m amsl.	Perm. power in % of rated power
<b>1000</b>	<b>100</b>
1500	97
2000	94
2500	90
3000	86
3500	82
4000	77



### Technical data

#### Rated currents

Rated power	Frame size/ No. of poles	Rated current $I_N$ ca. A to frame size 100 220–240/380–415 V from frame size 112 380–415 V $\Delta$ multiple-range voltage	Rated current $I_N$ ca. A to frame size 100 220/240 V from frame size 112 400 V $\Delta$ standard voltage
0.18	63 L / 4	–	0.95 / 0.57
	71 K / 4	1.1 / 0.64	–
	71 S / 6	1.3 / 0.75	1.08 / 0.62
	71 L / 8	–	1.35 / 0.76
0.25	71 S / 4	1.4 / 0.82	1.35 / 0.76
	71 L / 6	1.7 / 1.0	1.48 / 0.86
	80 S / 8	–	1.65 / 0.95
0.37	71 L / 4	2.1 / 1.2	1.8 / 1.0
	80 S / 6	2.4 / 1.4	2.3 / 1.35
	80 L / 8	–	2.5 / 1.45
0.55	80 S / 4	2.8 / 1.6	2.45 / 1.4
	80 L / 6	3.3 / 1.9	2.75 / 1.6
	90 L / 8	–	3.15 / 1.8
0.75	80 L / 4	3.5 / 2.0	3.3 / 1.9
	90 S / 6	4.3 / 2.5	3.8 / 2.2
	100 L / 8	–	3.8 / 2.2
1.1	90 S / 4	4.5 / 2.6	4.75 / 2.8
	90 L / 6	5.5 / 3.2	5.25 / 3.15
	100 L / 8	–	5.30 / 3.15
1.5	90 L / 4	6.0 / 3.5	6.1 / 3.5
	100 L / 6	6.7 / 3.9	6.75 / 3.9
	112 M / 8	–	5.15
2.2	100 L / 4	9.7 / 5.6	9.0 / 5.3
	112 M / 6	–	5.4
	132 S / 8	–	5.4
3.0	100 L / 4	12.6 / 7.3	12.2 / 7.1
	132 S / 6	–	7.4
	132 M / 8	–	7.6
4.0	112 M / 4	8.5	8.6
	132 M / 6	10.0	9.2
	132 M / 8	–	9.2
5.5	132 S / 4	11.5	11.0
	132 M / 6	–	12.7
	160 M / 8	–	11.4
7.5	132 M / 4	15.3	15.4
	160 M / 6	–	15.7
	160 L / 8	–	16.1
9.2	132 M / 4a	19.0	19.0
	180 M / 8	–	21.0
11	160 M / 4	22	22.0
	160 L / 6	–	22.0
	180 L / 8	–	23.5

The stated rated currents are approximate values.  
Technical alterations reserved.

# General data

## AC-motors

### Options – brakes

Brake motors are fitted with Lenze spring-loaded brakes (mounted between motor endshield and fan blade) under the fan cowl. When the motor is switched on, the brake is supplied with DC voltage via a suitable rectifier. The spring-loaded brake is a normally on, electromagnetically released brake comprising the stator (1), the armature (2) and the brake rotor (3). It is fixed to the motor endshield (5) with screws (4) and located under the fan cowl (6). The motor endshield serves as counter friction face. When the release current does not flow the springs (7)

press the armature (2) against the brake rotor (3), the rotor against the endshield (5). The braking torque is generated through friction on both friction faces. When switching on the motor, the brake release coil is activated and the magnetic force of the stator (1) releases the armature (2). The rotor (3) is released. The brake torque can be reduced by max. 40 % by using setting ring (8).

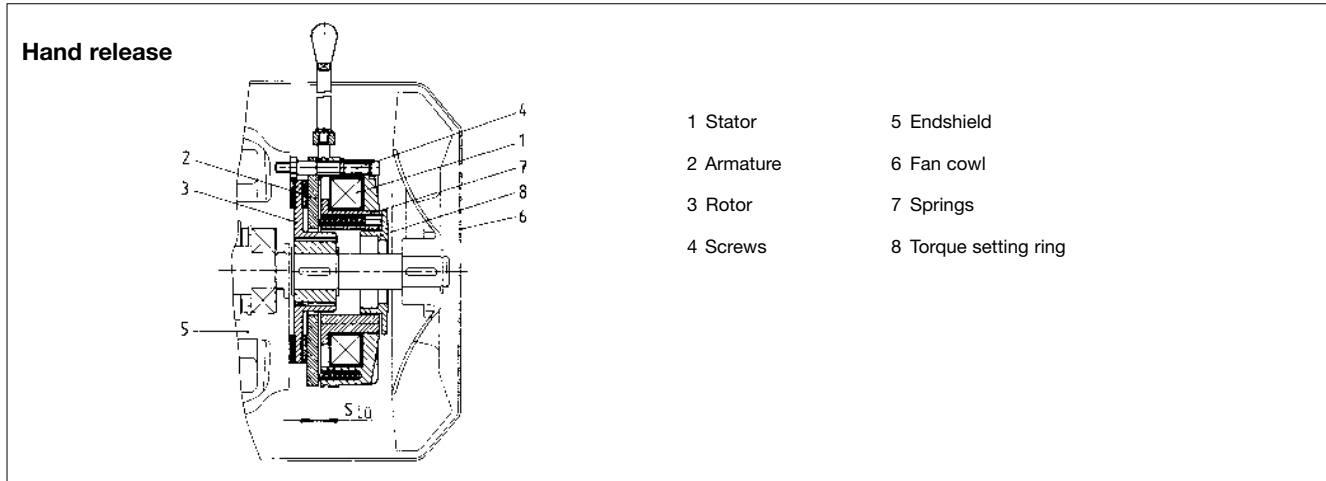

### Possible combinations Brake size – motor frame size

Motor frame size	Motor extension [mm]	Brake size							
		06	08	10	12	14	16	18	20
		Brake torque [Nm]							
		4	8	16	32	60	80	150	240
63	60	●	●						
71	68	●	●						
80	67		●	●					
90	75		●	●	●				
100	90			●	●	●			
112	95				●	●	●		
132	122					●	●	●	
160	130					●	●	●	●
<b>Extra weight [kg]</b>		0.75	1.25	2.5	3.8	5.8	9.0	14.5	23.5

### Hand release lever

This serves to manually release the brake and can be supplied at a surcharge.

### Options – Brakes

#### Brake voltage

As a rule, the brake coil voltage is designed so that it corresponds to the delta voltage of the motor (i. e. motor 230/400 V  $\Delta/\lambda$  = brake coil voltage = 230 Vac rectified). For motors which are star/delta started and with pole-changing motors, the brake voltage is designed according to the phase voltage of the mains supply.

$$\text{Phase voltage} = \frac{\text{supply voltage}}{\sqrt{3}}$$

Motor voltage	AC voltage input to the rectifier	Rated coil voltage	Rectifier	Type 4-pole	Type 6-pole
42/72 V	42 V ~	36 V	Full-wave	14.630.13.004/014	14.630.32.006/016
127/220 V	127 V ~	115 V	Full-wave	14.630.13.004/014	14.630.32.006/016
220/380 V	220 V ~	205 V	Full-wave	14.630.13.004/014	14.630.32.006/016
		103 V	Half-wave	14.630.14.004/014	14.630.33.006/016
230/400 V	230 V ~	205 V	Full-wave	14.630.13.004/014	14.630.32.006/016
		103 V	Half-wave	14.630.14.004/014	14.630.33.006/016
240/415 V	240 V ~	205 V	Full-wave	14.630.13.004/014	14.630.32.006/016
		103 V	Half-wave	14.630.14.004/014	14.630.33.006/016
255/440 V	255 V ~	215 V	Full-wave	14.630.13.004/014	14.630.32.006/016
		115 V	Half-wave	14.630.14.004/014	14.630.33.006/016
290/500 V	290 V ~	127 V	Half-wave	14.630.14.004/014	14.630.33.006/016
380 V $\Delta$	380 V ~	180 V	Half-wave	14.630.14.004/014	14.630.33.006/016
400 V $\Delta$	400 V ~	180 V	Half-wave	14.630.14.004/014	14.630.33.006/016
415 V $\Delta$	415 V ~	180 V	Half-wave	14.630.14.004/014	14.630.33.006/016
420 V $\Delta$	420 V ~	180 V	Half-wave	14.630.14.004/014	14.630.33.006/016
440 V $\Delta$	440 V ~	205 V	Half-wave	14.630.14.004/014	14.630.33.006/016
460 V $\Delta$	460 V ~	205 V	Half-wave	14.630.14.004/014	14.630.33.006/016
480 V $\Delta$	480 V ~	215 V	Half-wave	14.630.15.014	
500 V $\Delta$	500 V ~	215 V	Half-wave	14.630.15.014	

Standard voltages 24 V, 103 V, 180 V, 205 V

#### Note:

Max. direct current:

14.630.13/14.004/014: 1 A to 60 °C

14.630.32/33.006/016: 0.75 A to 60 °C

14.630.15.014: on request

Max. possible nominal coil voltage: 250 V DC



# ***Worm geared motors***

## ***Product information***

Illustrations _____	14
Type code _____	15
Order information _____	15

## ***Technical data***

Mounting positions _____	16
Terminal box positions _____	17

## ***Selection of worm geared motors***

Selection _____	18
Operating factors _____	18

## ***Drive selection***

Selection tables _____	19
Dimensions _____	36
Options _____	38

# Worm geared motors

## Product information

### Illustrations

Worm geared motors (motor mounting B14)

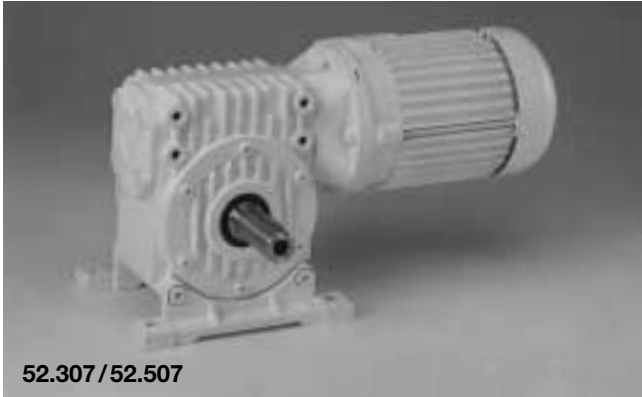

Worm geared motors (motor mounting B5)

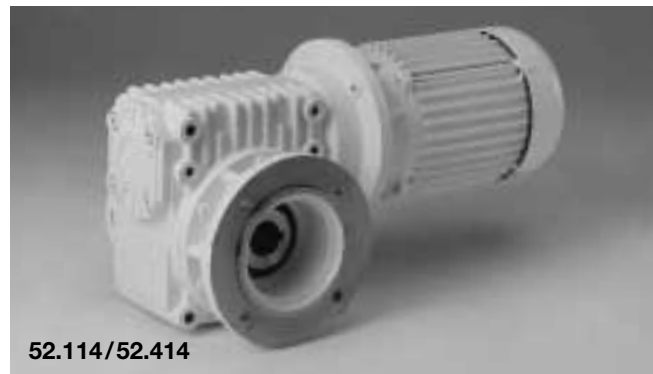

### Type code

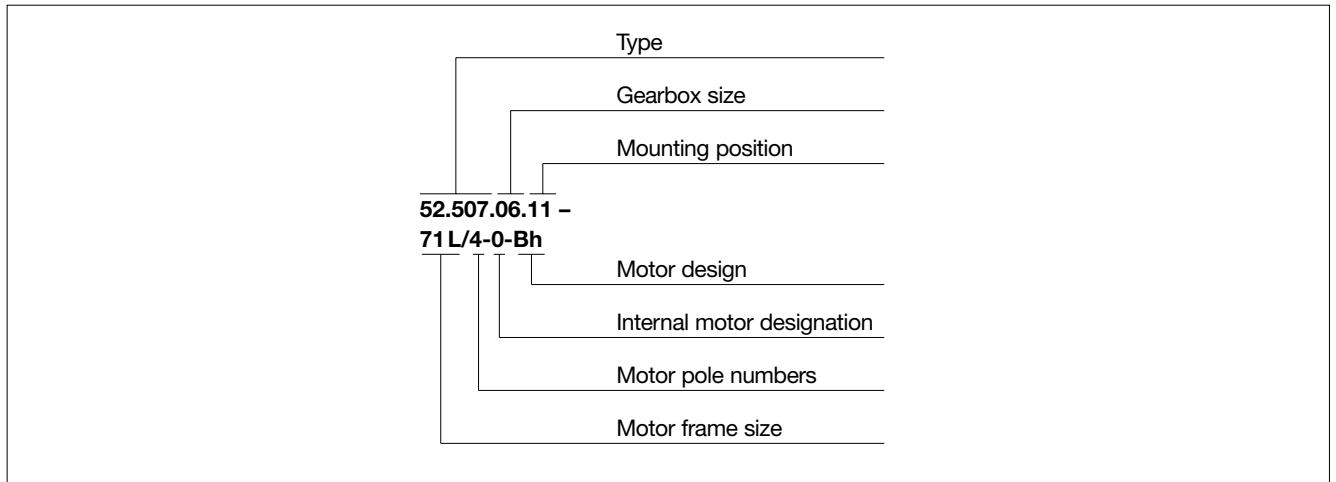

### Type

Design on output side	Type Worm geared motors	
	B 5-Motor	B 14-Motor
Foot mounted design	52.107/52.407	52.307/52.507
Flange mounted design	52.108/52.408	52.308/52.508
Hollow shaft design	52.109/52.409	52.309/52.509
Flange/Hollow shaft design	52.114/52.414	52.314/52.514

#### Gearbox size

04, 05, 06, 08, 10, 12

#### Internal motor designation

H, O, T, W – without influence on the motor data (will be indicated in the order confirmation).

#### Motor design

Br – with spring-loaded brake  
 Bh – with spring-loaded brake and hand release  
 Ex – explosion-proof  
 Fl – with separately driven fan  
 Ta – with tacho  
 Kt – with PTC thermistors  
 Th – with thermal circuit-breaker  
 Em – single phase motor

#### Order information

- complete type code
- Ratio
- Motor power and voltage
- Mounting position and position of the terminal box
- Flange design: Output flange diameter
- Hollow shaft design: hollow shaft bore
- Gearbox options
- Motor options

# Worm geared motors

## Technical data

### Mounting positions

with output shaft end

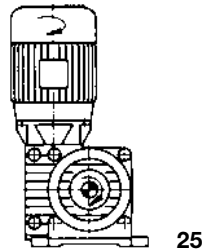
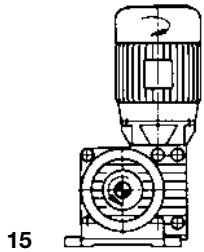
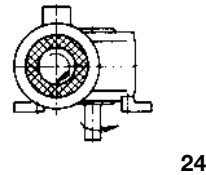
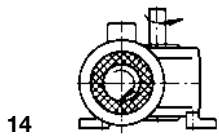
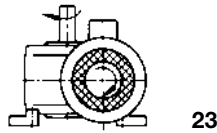
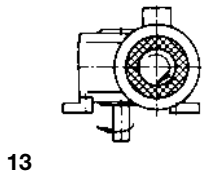
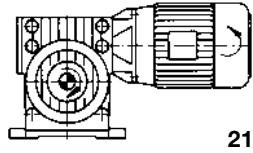
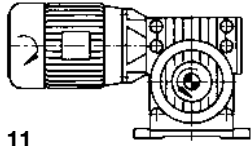
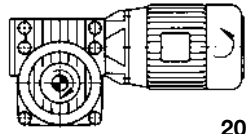
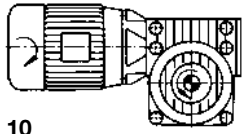

with output flange

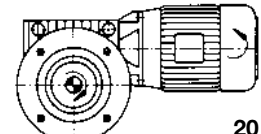
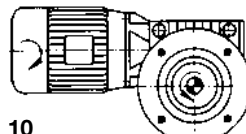

with hollow shaft

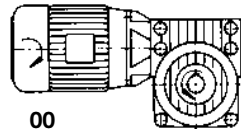

For output flange **and** hollow shaft the mounting position of the flange-mounted design applies.

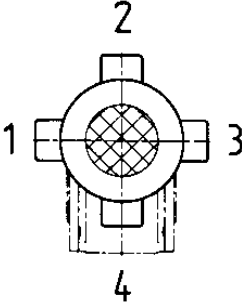
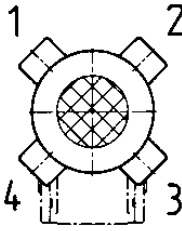

### Terminal box positions

Worm geared motors	
 <p>Fig. A</p>	 <p>Fig. B</p>
<p>Terminal box positions according to figure A or figure B depend on the gearbox size and motor flange diameter.</p>	

### Standard design:

With view of the motor blower the terminal box is in pos. 1.

Type		52.107...52.114 52.407...52.414	52.307...53.314 52.507...52.514
Gearbox size	Flange diameter	Fig.	
04	≤ 105 > 105	- A	B A
05	≤ 120 > 120	- A	B A
06	140 160 200	- - A	B A -
08	≤ 160 > 160	- A	B -
10	≤ 300	A	-
12	≤ 350	A	-

# Worm geared motors

## Selection

### Selection

Worm geared motors must be selected according to the input power  $P_1$  and the output speed  $n_2$ , as shown in the selection tables. Ensure that the  $c_s$  value shown in the table is equal to or greater than the larger of the two factors  $k_A$  and  $k_T$ . If, with the desired output speed ( $n_2$ ), the  $c_s$  value is smaller than the larger of the two values  $k_A$  and  $k_T$ , a slightly different speed ( $n_2$ ) fulfilling these conditions, or, with the same power, a motor with a larger gearbox must be selected. It may be necessary to select a geared motor from the next power class up.

$P_1$  = required motor power in kW

$n_2$  = output speed in rpm

$k_A$  = factor from the table

$k_T$  = factor from the table

### Operating factors

#### Factor $k_A$

Running time/d in h	Load class of the machine								
	I			II			III		
	Startings per h								
	< 10	10 ... 100	100 ... 400	< 10	10 ... 100	100 ... 400	< 10	10 ... 100	100 ... 400
< 0.5	0.80	0.90	1.00	0.90	1.00	1.15	1.00	1.15	1.25
> 0.5 ... 2	0.90	1.00	1.15	1.00	1.15	1.25	1.25	1.40	1.50
> 2 ... 10	1.00	1.15	1.25	1.25	1.40	1.50	1.50	1.70	1.80
> 10 ... 24	1.25	1.40	1.50	1.50	1.70	1.80	1.80	2.00	2.10

Load classes of the machine:

I = uniform load – virtually shock-free

II = medium load – moderate shocks

III = heavy load – strong shocks

Minimum operating factor with changing load:  $k_A = 1.40$

#### Factor $k_T$

Ambient temperature °C	Running time per hour				
	100 %	80 %	60 %	40 %	20 %
< 10	0.90	0.85	0.78	0.68	0.50
20	1.00	0.94	0.86	0.74	0.56
30	1.15	1.10	1.00	0.85	0.65
40	1.35	1.25	1.15	1.00	0.76
50	1.60	1.50	1.40	1.20	0.90

### Selection table

<b>P<sub>1</sub></b> Motor power <b>n<sub>2</sub></b> Output speed <b>M<sub>2</sub></b> Output torque <b>i</b> Ratio of the gearbox <b>c<sub>s</sub></b> Operating factor							
<b>P<sub>1</sub></b>	<b>n<sub>2</sub></b> [1/min]	<b>M<sub>2</sub></b> [Nm]	<b>c<sub>s</sub></b>	<b>Type</b> □ Mounting position (see page 16)	<b>i</b>	<b>Design</b>	<b>Dimensions</b> Page
<b>0.18 kW</b>	285	5.5	10.1	52.507.04.□-63L/4	5	1	36/37
				52.508.04.□-63L/4		2	
				52.509.04.□-63L/4		3	
				52.514.04.□-63L/4		4	
	190	8.0	7.6	52.507.04.□-63L/4	7	1	36/37
				52.508.04.□-63L/4		2	
				52.509.04.□-63L/4		3	
				52.514.04.□-63L/4		4	
	138	10	6.1	52.507.04.□-63L/4	10	1	36/37
				52.508.04.□-63L/4		2	
				52.509.04.□-63L/4		3	
				52.514.04.□-63L/4		4	
120	12	5.9	52.507.04.□-71S/6	7	1	36/37	
			52.508.04.□-71S/6		2		
			52.509.04.□-71S/6		3		
			52.514.04.□-71S/6		4		
95	14	4.5	52.507.04.□-63L/4	15	1	36/37	
			52.508.04.□-63L/4		2		
			52.509.04.□-63L/4		3		
			52.514.04.□-63L/4		4		
87	16	3.9	52.507.04.□-71S/6	10	1	36/37	
			52.508.04.□-71S/6		2		
			52.509.04.□-71S/6		3		
			52.514.04.□-71S/6		4		
69	19	3.7	52.507.04.□-63L/4	20	1	36/37	
			52.508.04.□-63L/4		2		
			52.509.04.□-63L/4		3		
			52.514.04.□-63L/4		4		
60	22	3.5	52.507.04.□-71S/6	15	1	36/37	
			52.508.04.□-71S/6		2		
			52.509.04.□-71S/6		3		
			52.514.04.□-71S/6		4		
47	24	2.6	52.507.04.□-63L/4	30	1	36/37	
			52.508.04.□-63L/4		2		
			52.509.04.□-63L/4		3		
			52.514.04.□-63L/4		4		
43	30	2.7	52.507.04.□-71S/6	20	1	36/37	
			52.508.04.□-71S/6		2		
			52.509.04.□-71S/6		3		
			52.514.04.□-71S/6		4		
34	32	2.2	52.507.04.□-63L/4	40	1	36/37	
			52.508.04.□-63L/4		2		
			52.509.04.□-63L/4		3		
			52.514.04.□-63L/4		4		
30	37	2.1	52.507.04.□-71S/6	30	1	36/37	
			52.508.04.□-71S/6		2		
			52.509.04.□-71S/6		3		
			52.514.04.□-71S/6		4		

Design

1 = Foot-mounted design

2 = Flange-mounted design

3 = Hollow-shaft design

4 = Flange-mounted/Hollow shaft design

# Worm geared motors

## Drive selection

### Selection table

<b>P<sub>1</sub></b> Motor power <b>n<sub>2</sub></b> Output speed <b>M<sub>2</sub></b> Output torque <b>i</b> Ratio of the gearbox <b>c<sub>s</sub></b> Operating factor							
<b>P<sub>1</sub></b>	<b>n<sub>2</sub></b> [1/min]	<b>M<sub>2</sub></b> [Nm]	<b>c<sub>s</sub></b>	<b>Type</b> □ Mounting position (see page 16)	<b>i</b>	<b>Design</b>	<b>Dimensions</b> Page
<b>0.18 kW</b>	26	38	1.3	52.507.04.□-63L/4 52.508.04.□-63L/4 52.509.04.□-63L/4 52.514.04.□-63L/4	53	1 2 3 4	36/37
	22	39	1.2	52.507.04.□-63L/4 52.508.04.□-63L/4 52.509.04.□-63L/4 52.514.04.□-63L/4	60	1 2 3 4	36/37
	21	48	1.7	52.507.04.□-71S/6 52.508.04.□-71S/6 52.509.04.□-71S/6 52.514.04.□-71S/6	40	1 2 3 4	36/37
	16	56	0.8	52.507.04.□-71S/6 52.508.04.□-71S/6 52.509.04.□-71S/6 52.514.04.□-71S/6	53	1 2 3 4	36/37
	16	59	1.4	52.507.05.□-71S/6 52.508.05.□-71S/6 52.509.05.□-71S/6 52.514.05.□-71S/6	53	1 2 3 4	36/37
	14	58	1.3	52.507.05.□-71S/6 52.508.05.□-71S/6 52.509.05.□-71S/6 52.514.05.□-71S/6	60	1 2 3 4	36/37
<b>0.25 kW</b>	285	7.6	7.2	52.507.04.□-71S/4 52.508.04.□-71S/4 52.509.04.□-71S/4 52.514.04.□-71S/4	5	1 2 3 4	36/37
	190	11	5.4	52.507.04.□-71S/4 52.508.04.□-71S/4 52.509.04.□-71S/4 52.514.04.□-71S/4	7	1 2 3 4	36/37
	145	14	6.9	52.507.05.□-71S/4 52.508.05.□-71S/4 52.509.05.□-71S/4 52.514.05.□-71S/4	10	1 2 3 4	36/37
	138	15	4.4	52.507.04.□-71S/4 52.508.04.□-71S/4 52.509.04.□-71S/4 52.514.04.□-71S/4	10	1 2 3 4	36/37
	125	16	4.3	52.507.04.□-71L/6 52.508.04.□-71L/6 52.509.04.□-71L/6 52.514.04.□-71L/6	7	1 2 3 4	36/37
	95	20	3.2	52.507.04.□-71S/4 52.508.04.□-71S/4 52.509.04.□-71S/4 52.514.04.□-71S/4	15	1 2 3 4	36/37
	91	22	2.9	52.507.04.□-71L/6 52.508.04.□-71L/6 52.509.04.□-71L/6 52.514.04.□-71L/6	10	1 2 3 4	36/37

### Selection table

<b>P<sub>1</sub></b> Motor power <b>n<sub>2</sub></b> Output speed <b>M<sub>2</sub></b> Output torque <b>i</b> Ratio of the gearbox <b>c<sub>s</sub></b> Operating factor							
<b>P<sub>1</sub></b>	<b>n<sub>2</sub></b> [1/min]	<b>M<sub>2</sub></b> [Nm]	<b>c<sub>s</sub></b>	<b>Type</b> □ Mounting position (see page 16)	<b>i</b>	<b>Design</b>	<b>Dimensions</b> Page
<b>0.25 kW</b>	69	27	2.7	52.507.04.□-71S/4	20	1	36/37
				52.508.04.□-71S/4		2	
				52.509.04.□-71S/4		3	
				52.514.04.□-71S/4		4	
	62	29	2.6	52.507.04.□-71L/6	15	1	36/37
				52.508.04.□-71L/6		2	
				52.509.04.□-71L/6		3	
				52.514.04.□-71L/6		4	
	47	34	1.9	52.507.04.□-71S/4	30	1	36/37
				52.508.04.□-71S/4		2	
				52.509.04.□-71S/4		3	
				52.514.04.□-71S/4		4	
45	40	2.0	52.507.04.□-71L/6	20	1	36/37	
			52.508.04.□-71L/6		2		
			52.509.04.□-71L/6		3		
			52.514.04.□-71L/6		4		
36	42	2.5	52.507.05.□-71S/4	40	1	36/37	
			52.508.05.□-71S/4		2		
			52.509.05.□-71S/4		3		
			52.514.05.□-71S/4		4		
34	45	1.6	52.507.04.□-71S/4	40	1	36/37	
			52.508.04.□-71S/4		2		
			52.509.04.□-71S/4		3		
			52.514.04.□-71S/4		4		
26	52	0.9	52.507.04.□-71S/4	53	1	36/37	
			52.508.04.□-71S/4		2		
			52.509.04.□-71S/4		3		
			52.514.04.□-71S/4		4		
26	55	1.5	52.507.05.□-71S/4	53	1	36/37	
			52.508.05.□-71S/4		2		
			52.509.05.□-71S/4		3		
			52.514.05.□-71S/4		4		
22	65	1.2	52.507.04.□-71L/6	40	1	36/37	
			52.508.04.□-71L/6		2		
			52.509.04.□-71L/6		3		
			52.514.04.□-71L/6		4		
22	54	0.8	52.507.04.□-71S/4	60	1	36/37	
			52.508.04.□-71S/4		2		
			52.509.04.□-71S/4		3		
			52.514.04.□-71S/4		4		
22	54	1.4	52.507.05.□-71S/4	60	1	36/37	
			52.508.05.□-71S/4		2		
			52.509.05.□-71S/4		3		
			52.514.05.□-71S/4		4		
17	79	1.1	52.507.05.□-71L/6	53	1	36/37	
			52.508.05.□-71L/6		2		
			52.509.05.□-71L/6		3		
			52.514.05.□-71L/6		4		

Design

1 = Foot-mounted design

2 = Flange-mounted design

3 = Hollow-shaft design

4 = Flange-mounted/Hollow shaft design

# Worm geared motors

## Drive selection

### Selection table

P <sub>1</sub> Motor power n <sub>2</sub> Output speed M <sub>2</sub> Output torque i Ratio of the gearbox c <sub>s</sub> Operating factor								
P <sub>1</sub>	n <sub>2</sub> [1/min]	M <sub>2</sub> [Nm]	c <sub>s</sub>	Type □ Mounting position (see page 16)	i	Design	Dimensions Page	
<b>0.25 kW</b>	14	78	1.0	52.507.05.□-71L/6	60	1	36/37	
				52.508.05.□-71L/6		2		
				52.509.05.□-71L/6		3		
				52.514.05.□-71L/6		4		
<b>0.37 kW</b>	287	11	4.9	52.507.04.□-71L/4	5	1	36/37	
				52.508.04.□-71L/4		2		
				52.509.04.□-71L/4		3		
				52.514.04.□-71L/4		4		
	191	16	3.7	3.7	52.507.04.□-71L/4	7	1	36/37
					52.508.04.□-71L/4		2	
					52.509.04.□-71L/4		3	
					52.514.04.□-71L/4		4	
	139	22	3.0	3.0	52.507.04.□-71L/4	10	1	36/37
					52.508.04.□-71L/4		2	
					52.509.04.□-71L/4		3	
					52.514.04.□-71L/4		4	
	124	24	2.9	2.9	52.507.04.□-80S/6	7	1	36/37
					52.508.04.□-80S/6		2	
					52.509.04.□-80S/6		3	
					52.514.04.□-80S/6		4	
95	29	2.2	2.2	52.507.04.□-71L/4	15	1	36/37	
				52.508.04.□-71L/4		2		
				52.509.04.□-71L/4		3		
				52.514.04.□-71L/4		4		
90	33	2.0	2.0	52.507.04.□-80S/6	10	1	36/37	
				52.508.04.□-80S/6		2		
				52.509.04.□-80S/6		3		
				52.514.04.□-80S/6		4		
73	38	2.8	2.8	52.507.05.□-71L/4	20	1	36/37	
				52.508.05.□-71L/4		2		
				52.509.05.□-71L/4		3		
				52.514.05.□-71L/4		4		
69	39	1.8	1.8	52.507.04.□-71L/4	20	1	36/37	
				52.508.04.□-71L/4		2		
				52.509.04.□-71L/4		3		
				52.514.04.□-71L/4		4		
62	44	1.7	1.7	52.507.04.□-80S/6	15	1	36/37	
				52.508.04.□-80S/6		2		
				52.509.04.□-80S/6		3		
				52.514.04.□-80S/6		4		
47	50	1.3	1.3	52.507.04.□-71L/4	30	1	36/37	
				52.508.04.□-71L/4		2		
				52.509.04.□-71L/4		3		
				52.514.04.□-71L/4		4		
47	51	1.9	1.9	52.507.05.□-71L/4	30	1	36/37	
				52.508.05.□-71L/4		2		
				52.509.05.□-71L/4		3		
				52.514.05.□-71L/4		4		
45	60	1.4	1.4	52.507.04.□-80S/6	20	1	36/37	
				52.508.04.□-80S/6		2		
				52.509.04.□-80S/6		3		
				52.514.04.□-80S/6		4		

### Selection table

<b>P<sub>1</sub></b> Motor power <b>n<sub>2</sub></b> Output speed <b>M<sub>2</sub></b> Output torque <b>i</b> Ratio of the gearbox <b>c<sub>s</sub></b> Operating factor							
<b>P<sub>1</sub></b>	<b>n<sub>2</sub></b> [1/min]	<b>M<sub>2</sub></b> [Nm]	<b>c<sub>s</sub></b>	<b>Type</b> □ Mounting position (see page 16)	<b>i</b>	<b>Design</b>	<b>Dimensions</b> Page
<b>0.37 kW</b>	36	63	1.7	52.507.05.□-71L/4	40	1	36/37
				52.508.05.□-71L/4		2	
				52.509.05.□-71L/4		3	
				52.514.05.□-71L/4		4	
	34	66	1.1	52.507.04.□-71L/4	40	1	36/37
				52.508.04.□-71L/4		2	
				52.509.04.□-71L/4		3	
				52.514.04.□-71L/4		4	
	31	75	1.0	52.507.04.□-80S/6	30	1	36/37
				52.508.04.□-80S/6		2	
52.509.04.□-80S/6				3			
52.514.04.□-80S/6				4			
31	77	1.6	52.507.05.□-80S/6	30	1	36/37	
			52.508.05.□-80S/6		2		
			52.509.05.□-80S/6		3		
			52.514.05.□-80S/6		4		
26	81	1.0	52.507.05.□-71L/4	53	1	36/37	
			52.508.05.□-71L/4		2		
			52.509.05.□-71L/4		3		
			52.514.05.□-71L/4		4		
23	94	1.4	52.507.05.□-80S/6	40	1	36/37	
			52.508.05.□-80S/6		2		
			52.509.05.□-80S/6		3		
			52.514.05.□-80S/6		4		
22	80	1.0	52.507.05.□-71L/4	60	1	36/37	
			52.508.05.□-71L/4		2		
			52.509.05.□-71L/4		3		
			52.514.05.□-71L/4		4		
17	123	2.0	52.307.06.□-80S/6	53	1	36/37	
			52.308.06.□-80S/6		2		
			52.309.06.□-80S/6		3		
			52.314.06.□-80S/6		4		
14	124	1.5	52.307.06.□-80S/6	60	1	36/37	
			52.308.06.□-80S/6		2		
			52.309.06.□-80S/6		3		
			52.314.06.□-80S/6		4		
<b>0.55 kW</b>	285	16	3.3	52.507.04.□-80S/4	5	1	36/37
				52.508.04.□-80S/4		2	
				52.509.04.□-80S/4		3	
52.514.04.□-80S/4				4			
190	24	2.5	52.507.04.□-80S/4	7	1	36/37	
			52.508.04.□-80S/4		2		
			52.509.04.□-80S/4		3		
			52.514.04.□-80S/4		4		
138	33	2.0	52.507.04.□-80S/4	10	1	36/37	
			52.508.04.□-80S/4		2		
			52.509.04.□-80S/4		3		
			52.514.04.□-80S/4		4		

Design

1 = Foot-mounted design

2 = Flange-mounted design

3 = Hollow-shaft design

4 = Flange-mounted/Hollow shaft design

# Worm geared motors

## Drive selection

### Selection table

<b>P<sub>1</sub></b> Motor power <b>n<sub>2</sub></b> Output speed <b>M<sub>2</sub></b> Output torque <b>i</b> Ratio of the gearbox <b>c<sub>s</sub></b> Operating factor							
<b>P<sub>1</sub></b>	<b>n<sub>2</sub></b> [1/min]	<b>M<sub>2</sub></b> [Nm]	<b>c<sub>s</sub></b>	<b>Type</b> □ Mounting position (see page 16)	<b>i</b>	<b>Design</b>	<b>Dimensions</b> Page
<b>0.55 kW</b>	122	37	1.9	52.507.04.□-80L/6 52.508.04.□-80L/6 52.509.04.□-80L/6 52.514.04.□-80L/6	7	1 2 3 4	36/37
	95	45	2.2	52.507.05.□-80S/4 52.508.05.□-80S/4 52.509.05.□-80S/4 52.514.05.□-80S/4	15	1 2 3 4	36/37
	72	57	1.9	52.507.05.□-80S/4 52.508.05.□-80S/4 52.509.05.□-80S/4 52.514.05.□-80S/4	20	1 2 3 4	36/37
	61	68	1.8	52.507.05.□-80L/6 52.508.05.□-80L/6 52.509.05.□-80L/6 52.514.05.□-80L/6	15	1 2 3 4	36/37
	47	77	1.3	52.507.05.□-80S/4 52.508.05.□-80S/4 52.509.05.□-80S/4 52.514.05.□-80S/4	30	1 2 3 4	36/37
	36	94	1.2	52.507.05.□-80S/4 52.508.05.□-80S/4 52.509.05.□-80S/4 52.514.05.□-80S/4	40	1 2 3 4	36/37
	35	99	1.9	52.307.06.□-80S/4 52.308.06.□-80S/4 52.309.06.□-80S/4 52.314.06.□-80S/4	40	1 2 3 4	36/37
	30	116	1.1	52.507.05.□-80L/6 52.508.05.□-80L/6 52.509.05.□-80L/6 52.514.05.□-80L/6	30	1 2 3 4	36/37
	30	118	1.7	52.307.06.□-80L/6 52.308.06.□-80L/6 52.309.06.□-80L/6 52.314.06.□-80L/6	30	1 2 3 4	36/37
	27	123	1.7	52.307.06.□-80S/4 52.308.06.□-80S/4 52.309.06.□-80S/4 52.314.06.□-80S/4	53	1 2 3 4	36/37
	23	142	0.9	52.507.05.□-80L/6 52.508.05.□-80L/6 52.509.05.□-80L/6 52.514.05.□-80L/6	40	1 2 3 4	36/37
	22	128	1.3	52.307.06.□-80S/4 52.308.06.□-80S/4 52.309.06.□-80S/4 52.314.06.□-80S/4	60	1 2 3 4	36/37
	22	140	2.1	52.307.08.□-80S/4 52.308.08.□-80S/4 52.309.08.□-80S/4 52.314.08.□-80S/4	60	1 2 3 4	36/37



### Selection table

<b>P<sub>1</sub></b> Motor power <b>n<sub>2</sub></b> Output speed <b>M<sub>2</sub></b> Output torque <b>i</b> Ratio of the gearbox <b>c<sub>s</sub></b> Operating factor							
<b>P<sub>1</sub></b>	<b>n<sub>2</sub></b> [1/min]	<b>M<sub>2</sub></b> [Nm]	<b>c<sub>s</sub></b>	<b>Type</b> □ Mounting position (see page 16)	<b>i</b>	<b>Design</b>	<b>Dimensions</b> Page
<b>0.55 kW</b>	17	184	1.3	52.307.06.□-80L/6 52.308.06.□-80L/6 52.309.06.□-80L/6 52.314.06.□-80L/6	53	1 2 3 4	36/37
	16	201	2.1	52.307.08.□-80L/6 52.308.08.□-80L/6 52.309.08.□-80L/6 52.314.08.□-80L/6	53	1 2 3 4	36/37
	14	186	1.0	52.307.06.□-80L/6 52.308.06.□-80L/6 52.309.06.□-80L/6 52.314.06.□-80L/6	60	1 2 3 4	36/37
	14	208	1.7	52.307.08.□-80L/6 52.308.08.□-80L/6 52.309.08.□-80L/6 52.314.08.□-80L/6	60	1 2 3 4	36/37
<b>0.75 kW</b>	285	22	2.4	52.507.04.□-80L/4 52.508.04.□-80L/4 52.509.04.□-80L/4 52.514.04.□-80L/4	5	1 2 3 4	36/37
	190	33	1.8	52.507.04.□-80L/4 52.508.04.□-80L/4 52.509.04.□-80L/4 52.514.04.□-80L/4	7	1 2 3 4	36/37
	145	43	2.3	52.507.05.□-80L/4 52.508.05.□-80L/4 52.509.05.□-80L/4 52.514.05.□-80L/4	10	1 2 3 4	36/37
	95	61	1.6	52.507.05.□-80L/4 52.508.05.□-80L/4 52.509.05.□-80L/4 52.514.05.□-80L/4	15	1 2 3 4	36/37
	72	77	1.4	52.507.05.□-80L/4 52.508.05.□-80L/4 52.509.05.□-80L/4 52.514.05.□-80L/4	20	1 2 3 4	36/37
	70	81	2.3	52.307.06.□-80L/4 52.308.06.□-80L/4 52.309.06.□-80L/4 52.314.06.□-80L/4	20	1 2 3 4	36/37
	64	91	2.2	52.307.06.□-90S/6 52.308.06.□-90S/6 52.309.06.□-90S/6 52.314.06.□-90S/6	15	1 2 3 4	36/37
	47	105	0.9	52.507.05.□-80L/4 52.508.05.□-80L/4 52.509.05.□-80L/4 52.514.05.□-80L/4	30	1 2 3 4	36/37

Design

1 = Foot-mounted design

2 = Flange-mounted design

3 = Hollow-shaft design

4 = Flange-mounted/Hollow shaft design

# Worm geared motors

## Drive selection

### Selection table

<b>P<sub>1</sub></b> Motor power <b>n<sub>2</sub></b> Output speed <b>M<sub>2</sub></b> Output torque <b>i</b> Ratio of the gearbox <b>c<sub>s</sub></b> Operating factor							
<b>P<sub>1</sub></b>	<b>n<sub>2</sub></b> [1/min]	<b>M<sub>2</sub></b> [Nm]	<b>c<sub>s</sub></b>	<b>Type</b> □ Mounting position (see page 16)	<b>i</b>	<b>Design</b>	<b>Dimensions</b> Page
<b>0.75 kW</b>	47	107	1.6	52.307.06.□-80L/4 52.308.06.□-80L/4 52.309.06.□-80L/4 52.314.06.□-80L/4	30	1 2 3 4	36/37
	36	128	0.8	52.507.05.□-80L/4 52.508.05.□-80L/4 52.509.05.□-80L/4 52.514.05.□-80L/4	40	1 2 3 4	36/37
	35	136	1.4	52.307.06.□-80L/4 52.308.06.□-80L/4 52.309.06.□-80L/4 52.314.06.□-80L/4	40	1 2 3 4	36/37
	34	148	2.2	52.307.08.□-80L/4 52.308.08.□-80L/4 52.309.08.□-80L/4 52.314.08.□-80L/4	40	1 2 3 4	36/37
	27	167	1.3	52.307.06.□-80L/4 52.308.06.□-80L/4 52.309.06.□-80L/4 52.314.06.□-80L/4	53	1 2 3 4	36/37
	26	185	2.0	52.307.08.□-80L/4 52.308.08.□-80L/4 52.309.08.□-80L/4 52.314.08.□-80L/4	53	1 2 3 4	36/37
	23	197	1.2	52.307.06.□-90S/6 52.308.06.□-90S/6 52.309.06.□-90S/6 52.314.06.□-90S/6	40	1 2 3 4	36/37
	22	175	1.0	52.307.06.□-80L/4 52.308.06.□-80L/4 52.309.06.□-80L/4 52.314.06.□-80L/4	60	1 2 3 4	36/37
	22	191	1.6	52.307.08.□-80L/4 52.308.08.□-80L/4 52.309.08.□-80L/4 52.314.08.□-80L/4	60	1 2 3 4	36/37
	18	242	1.0	52.307.06.□-90S/6 52.308.06.□-90S/6 52.309.06.□-90S/6 52.314.06.□-90S/6	53	1 2 3 4	36/37
	17	263	1.6	52.307.08.□-90S/6 52.308.08.□-90S/6 52.309.08.□-90S/6 52.314.08.□-90S/6	53	1 2 3 4	36/37
	15	273	1.3	52.307.08.□-90S/6 52.308.08.□-90S/6 52.309.08.□-90S/6 52.314.08.□-90S/6	60	1 2 3 4	36/37
<b>1.1 kW</b>	289	33	4.1	52.307.06.□-90S/4 52.308.06.□-90S/4 52.309.06.□-90S/4 52.314.06.□-90S/4	5	1 2 3 4	36/37

### Selection table

<b>P<sub>1</sub></b> Motor power <b>n<sub>2</sub></b> Output speed <b>M<sub>2</sub></b> Output torque <b>i</b> Ratio of the gearbox <b>c<sub>s</sub></b> Operating factor							
<b>P<sub>1</sub></b>	<b>n<sub>2</sub></b> [1/min]	<b>M<sub>2</sub></b> [Nm]	<b>c<sub>s</sub></b>	<b>Type</b> □ Mounting position (see page 16)	<b>i</b>	<b>Design</b>	<b>Dimensions</b> Page
<b>1.1 kW</b>	193	49	3.1	52.307.06.□-90S/4	7	1	36/37
				52.308.06.□-90S/4		2	
				52.309.06.□-90S/4		3	
				52.314.06.□-90S/4		4	
	143	65	2.7	52.307.06.□-90S/4	10	1	36/37
				52.308.06.□-90S/4		2	
				52.309.06.□-90S/4		3	
				52.314.06.□-90S/4		4	
	128	73	2.5	52.307.06.□-90L/6	7	1	36/37
				52.308.06.□-90L/6		2	
				52.309.06.□-90L/6		3	
				52.314.06.□-90L/6		4	
96	90	1.8	52.307.06.□-90S/4	15	1	36/37	
			52.308.06.□-90S/4		2		
			52.309.06.□-90S/4		3		
			52.314.06.□-90S/4		4		
71	117	1.6	52.307.06.□-90S/4	20	1	36/37	
			52.308.06.□-90S/4		2		
			52.309.06.□-90S/4		3		
			52.314.06.□-90S/4		4		
64	133	1.5	52.307.06.□-90L/6	15	1	36/37	
			52.308.06.□-90L/6		2		
			52.309.06.□-90L/6		3		
			52.314.06.□-90L/6		4		
48	155	1.1	52.307.06.□-90S/4	30	1	36/37	
			52.308.06.□-90S/4		2		
			52.309.06.□-90S/4		3		
			52.314.06.□-90S/4		4		
46	167	1.8	52.307.08.□-90S/4	30	1	36/37	
			52.308.08.□-90S/4		2		
			52.309.08.□-90S/4		3		
			52.314.08.□-90S/4		4		
35	197	1.0	52.307.06.□-90S/4	40	1	36/37	
			52.308.06.□-90S/4		2		
			52.309.06.□-90S/4		3		
			52.314.06.□-90S/4		4		
35	214	1.5	52.307.08.□-90S/4	40	1	36/37	
			52.308.08.□-90S/4		2		
			52.309.08.□-90S/4		3		
			52.314.08.□-90S/4		4		
32	227	0.9	52.307.06.□-90L/6	30	1	36/37	
			52.308.06.□-90L/6		2		
			52.309.06.□-90L/6		3		
			52.314.06.□-90L/6		4		
31	244	1.4	52.307.08.□-90L/6	30	1	36/37	
			52.308.08.□-90L/6		2		
			52.309.08.□-90L/6		3		
			52.314.08.□-90L/6		4		

Design

1 = Foot-mounted design

2 = Flange-mounted design

3 = Hollow-shaft design

4 = Flange-mounted/Hollow shaft design

# Worm geared motors

## Drive selection

### Selection table

P <sub>1</sub> Motor power n <sub>2</sub> Output speed M <sub>2</sub> Output torque i Ratio of the gearbox c <sub>s</sub> Operating factor							
P <sub>1</sub>	n <sub>2</sub> [1/min]	M <sub>2</sub> [Nm]	c <sub>s</sub>	Type □ Mounting position (see page 16)	i	Design	Dimensions Page
<b>1.1 kW</b>	27	242	0.9	52.307.06.□-90S/4 52.308.06.□-90S/4 52.309.06.□-90S/4 52.314.06.□-90S/4	53	1 2 3 4	36/37
	26	278	2.1	52.107.10.□-90S/4 52.108.10.□-90S/4 52.109.10.□-90S/4 52.114.10.□-90S/4	53	1 2 3 4	36/37
	26	268	1.4	52.307.08.□-90S/4 52.308.08.□-90S/4 52.309.08.□-90S/4 52.314.08.□-90S/4	53	1 2 3 4	36/37
	22	276	1.1	52.307.08.□-90S/4 52.308.08.□-90S/4 52.309.08.□-90S/4 52.314.08.□-90S/4	60	1 2 3 4	36/37
	22	295	1.6	52.107.10.□-90S/4 52.108.10.□-90S/4 52.109.10.□-90S/4 52.114.10.□-90S/4	60	1 2 3 4	36/37
<b>1.5 kW</b>	293	45	3.1	52.307.06.□-90L/4 52.308.06.□-90L/4 52.309.06.□-90L/4 52.314.06.□-90L/4	5	1 2 3 4	36/37
	195	66	2.3	52.307.06.□-90L/4 52.308.06.□-90L/4 52.309.06.□-90L/4 52.314.06.□-90L/4	7	1 2 3 4	36/37
	145	87	2.0	52.307.06.□-90L/4 52.308.06.□-90L/4 52.309.06.□-90L/4 52.314.06.□-90L/4	10	1 2 3 4	36/37
	97	121	1.4	52.307.06.□-90L/4 52.308.06.□-90L/4 52.309.06.□-90L/4 52.314.06.□-90L/4	15	1 2 3 4	36/37
	94	129	2.2	52.307.08.□-90L/4 52.308.08.□-90L/4 52.309.08.□-90L/4 52.314.08.□-90L/4	15	1 2 3 4	36/37
	72	158	1.2	52.307.06.□-90L/4 52.308.06.□-90L/4 52.309.06.□-90L/4 52.314.06.□-90L/4	20	1 2 3 4	36/37
	71	167	1.9	52.307.08.□-90L/4 52.308.08.□-90L/4 52.309.08.□-90L/4 52.314.08.□-90L/4	20	1 2 3 4	36/37
	48	209	0.8	52.307.06.□-90L/4 52.308.06.□-90L/4 52.309.06.□-90L/4 52.314.06.□-90L/4	30	1 2 3 4	36/37

### Selection table

<b>P<sub>1</sub></b> Motor power <b>n<sub>2</sub></b> Output speed <b>M<sub>2</sub></b> Output torque <b>i</b> Ratio of the gearbox <b>c<sub>s</sub></b> Operating factor							
<b>P<sub>1</sub></b>	<b>n<sub>2</sub></b> [1/min]	<b>M<sub>2</sub></b> [Nm]	<b>c<sub>s</sub></b>	<b>Type</b> □ Mounting position (see page 16)	<b>i</b>	<b>Design</b>	<b>Dimensions</b> Page
<b>1.5 kW</b>	47	228	1.8	52.107.10.□- 90L/4	30	1	36/37
				52.108.10.□- 90L/4		2	
				52.109.10.□- 90L/4		3	
				52.114.10.□- 90L/4		4	
	47	225	1.3	52.307.08.□- 90L/4	30	1	36/37
				52.308.08.□- 90L/4		2	
				52.309.08.□- 90L/4		3	
				52.314.08.□- 90L/4		4	
	35	288	1.1	52.307.08.□- 90L/4	40	1	36/37
				52.308.08.□- 90L/4		2	
				52.309.08.□- 90L/4		3	
				52.314.08.□- 90L/4		4	
35	300	1.8	52.107.10.□- 90L/4	40	1	36/37	
			52.108.10.□- 90L/4		2		
			52.109.10.□- 90L/4		3		
			52.114.10.□- 90L/4		4		
31	332	1.0	52.307.08.□- 100L/6	30	1	36/37	
			52.308.08.□- 100L/6		2		
			52.309.08.□- 100L/6		3		
			52.314.08.□- 100L/6		4		
31	336	1.4	52.107.10.□- 100L/6	30	1	36/37	
			52.108.10.□- 100L/6		2		
			52.109.10.□- 100L/6		3		
			52.114.10.□- 100L/6		4		
27	374	1.5	52.107.10.□- 90L/4	53	1	36/37	
			52.108.10.□- 90L/4		2		
			52.109.10.□- 90L/4		3		
			52.114.10.□- 90L/4		4		
26	360	1.0	52.307.08.□- 90L/4	53	1	36/37	
			52.308.08.□- 90L/4		2		
			52.309.08.□- 90L/4		3		
			52.314.08.□- 90L/4		4		
22	397	1.2	52.107.10.□- 90L/4	60	1	36/37	
			52.108.10.□- 90L/4		2		
			52.109.10.□- 90L/4		3		
			52.114.10.□- 90L/4		4		
18	552	1.2	52.107.10.□- 100L/6	53	1	36/37	
			52.108.10.□- 100L/6		2		
			52.109.10.□- 100L/6		3		
			52.114.10.□- 100L/6		4		
15	582	1.0	52.107.10.□- 100L/6	60	1	36/37	
			52.108.10.□- 100L/6		2		
			52.109.10.□- 100L/6		3		
			52.114.10.□- 100L/6		4		
<b>2.2 kW</b>	141	133	2.2	52.307.08.□- 100 /4	10	1	36/37
				52.308.08.□- 100 /4		2	
				52.309.08.□- 100 /4		3	
				52.314.08.□- 100 /4		4	

Design

1 = Foot-mounted design

2 = Flange-mounted design

3 = Hollow-shaft design

4 = Flange-mounted/Hollow shaft design

# Worm geared motors

## Drive selection

### Selection table

P <sub>1</sub> Motor power n <sub>2</sub> Output speed M <sub>2</sub> Output torque i Ratio of the gearbox c <sub>s</sub> Operating factor							
P <sub>1</sub>	n <sub>2</sub> [1/min]	M <sub>2</sub> [Nm]	c <sub>s</sub>	Type □ Mounting position (see page 16)	i	Design	Dimensions Page
<b>2.2 kW</b>	128	149	2.0	52.307.08.□-112M/6 52.308.08.□-112M/6 52.309.08.□-112M/6 52.314.08.□-112M/6	7	1 2 3 4	36/37
	94	190	1.5	52.307.08.□-100 /4 52.308.08.□-100 /4 52.309.08.□-100 /4 52.314.08.□-100 /4	15	1 2 3 4	36/37
	94	193	2.3	52.107.10.□-100 /4 52.108.10.□-100 /4 52.109.10.□-100 /4 52.114.10.□-100 /4	15	1 2 3 4	36/37
	70	252	2.0	52.107.10.□-100 /4 52.108.10.□-100 /4 52.109.10.□-100 /4 52.114.10.□-100 /4	20	1 2 3 4	36/37
	70	246	1.3	52.307.08.□-100 /4 52.308.08.□-100 /4 52.309.08.□-100 /4 52.314.08.□-100 /4	20	1 2 3 4	36/37
	64	275	1.2	52.307.08.□-112M/6 52.308.08.□-112M/6 52.309.08.□-112M/6 52.314.08.□-112M/6	15	1 2 3 4	36/37
	48	344	2.2	52.107.12.□-100 /4 52.108.12.□-100 /4 52.109.12.□-100 /4 52.114.12.□-100 /4	30	1 2 3 4	36/37
	48	366	1.6	52.107.10.□-112M/6 52.108.10.□-112M/6 52.109.10.□-112M/6 52.114.10.□-112M/6	20	1 2 3 4	36/37
	47	331	0.9	52.307.08.□-100 /4 52.308.08.□-100 /4 52.309.08.□-100 /4 52.314.08.□-100 /4	30	1 2 3 4	36/37
	47	336	1.2	52.107.10.□-100 /4 52.108.10.□-100 /4 52.109.10.□-100 /4 52.114.10.□-100 /4	30	1 2 3 4	36/37
	35	463	2.0	52.107.12.□-100 /4 52.108.12.□-100 /4 52.109.12.□-100 /4 52.114.12.□-100 /4	40	1 2 3 4	36/37
	35	442	1.2	52.107.10.□-100 /4 52.108.10.□-100 /4 52.109.10.□-100 /4 52.114.10.□-100 /4	40	1 2 3 4	36/37
	27	579	1.8	52.107.12.□-100 /4 52.108.12.□-100 /4 52.109.12.□-100 /4 52.114.12.□-100 /4	53	1 2 3 4	36/37

### Selection table

<b>P<sub>1</sub></b> Motor power <b>n<sub>2</sub></b> Output speed <b>M<sub>2</sub></b> Output torque <b>i</b> Ratio of the gearbox <b>c<sub>s</sub></b> Operating factor							
<b>P<sub>1</sub></b>	<b>n<sub>2</sub></b> [1/min]	<b>M<sub>2</sub></b> [Nm]	<b>c<sub>s</sub></b>	<b>Type</b> □ Mounting position (see page 16)	<b>i</b>	<b>Design</b>	<b>Dimensions</b> Page
<b>2.2 kW</b>	27	551	1.0	52.107.10.□-100 /4	53	1	36/37
				52.108.10.□-100 /4		2	
				52.109.10.□-100 /4		3	
				52.114.10.□-100 /4		4	
	22	616	1.4	52.107.12.□-100 /4	60	1	36/37
52.108.12.□-100 /4				2			
52.109.12.□-100 /4				3			
52.114.12.□-100 /4				4			
18	794	0.8	52.107.10.□-112M/6	53	1	36/37	
			52.108.10.□-112M/6		2		
			52.109.10.□-112M/6		3		
			52.114.10.□-112M/6		4		
18	839	1.5	52.107.12.□-112M/6	53	1	36/37	
			52.108.12.□-112M/6		2		
			52.109.12.□-112M/6		3		
			52.114.12.□-112M/6		4		
15	892	1.1	52.107.12.□-112M/6	60	1	36/37	
			52.108.12.□-112M/6		2		
			52.109.12.□-112M/6		3		
			52.114.12.□-112M/6		4		
<b>3.0 kW</b>	280	96	2.4	52.307.08.□-100L /4	5	1	36/37
				52.308.08.□-100L /4		2	
				52.309.08.□-100L /4		3	
				52.314.08.□-100L /4		4	
	186	139	1.9	52.307.08.□-100L /4	7	1	36/37
				52.308.08.□-100L /4		2	
				52.309.08.□-100L /4		3	
				52.314.08.□-100L /4		4	
140	184	1.6	52.307.08.□-100L /4	10	1	36/37	
			52.308.08.□-100L /4		2		
			52.309.08.□-100L /4		3		
			52.314.08.□-100L /4		4		
93	262	1.1	52.307.08.□-100L /4	15	1	36/37	
			52.308.08.□-100L /4		2		
			52.309.08.□-100L /4		3		
			52.314.08.□-100L /4		4		
93	267	1.7	52.107.10.□-100L /4	15	1	36/37	
			52.108.10.□-100L /4		2		
			52.109.10.□-100L /4		3		
			52.114.10.□-100L /4		4		
70	347	1.5	52.107.10.□-100L /4	20	1	36/37	
			52.108.10.□-100L /4		2		
			52.109.10.□-100L /4		3		
			52.114.10.□-100L /4		4		
70	339	0.9	52.307.08.□-100L /4	20	1	36/37	
			52.308.08.□-100L /4		2		
			52.309.08.□-100L /4		3		
			52.314.08.□-100L /4		4		

Design

1 = Foot-mounted design

2 = Flange-mounted design

3 = Hollow-shaft design

4 = Flange-mounted/Hollow shaft design

# Worm geared motors

## Drive selection

### Selection table

<b>P<sub>1</sub></b> Motor power <b>n<sub>2</sub></b> Output speed <b>M<sub>2</sub></b> Output torque <b>i</b> Ratio of the gearbox <b>c<sub>s</sub></b> Operating factor							
<b>P<sub>1</sub></b>	<b>n<sub>2</sub></b> [1/min]	<b>M<sub>2</sub></b> [Nm]	<b>c<sub>s</sub></b>	<b>Type</b> □ Mounting position (see page 16)	<b>i</b>	<b>Design</b>	<b>Dimensions</b> Page
<b>3.0 kW</b>	48	474	1.6	52.107.12.□-100L/4 52.108.12.□-100L/4 52.109.12.□-100L/4 52.114.12.□-100L/4	30	1 2 3 4	36/37
	46	463	0.9	52.107.10.□-100L/4 52.108.10.□-100L/4 52.109.10.□-100L/4 52.114.10.□-100L/4	30	1 2 3 4	36/37
	35	638	1.4	52.107.12.□-100L/4 52.108.12.□-100L/4 52.109.12.□-100L/4 52.114.12.□-100L/4	40	1 2 3 4	36/37
	35	609	0.9	52.107.10.□-100L/4 52.108.10.□-100L/4 52.109.10.□-100L/4 52.114.10.□-100L/4	40	1 2 3 4	36/37
	32	711	1.4	52.107.12.□-132S/6 52.108.12.□-132S/6 52.109.12.□-132S/6 52.114.12.□-132S/6	30	1 2 3 4	36/37
	26	798	1.3	52.107.12.□-100L/4 52.108.12.□-100L/4 52.109.12.□-100L/4 52.114.12.□-100L/4	53	1 2 3 4	36/37
	22	850	1.0	52.107.12.□-100L/4 52.108.12.□-100L/4 52.109.12.□-100L/4 52.114.12.□-100L/4	60	1 2 3 4	36/37
<b>4.0 kW</b>	286	125	1.9	52.307.08.□-112M/4 52.308.08.□-112M/4 52.309.08.□-112M/4 52.314.08.□-112M/4	5	1 2 3 4	36/37
	190	182	1.4	52.307.08.□-112M/4 52.308.08.□-112M/4 52.309.08.□-112M/4 52.314.08.□-112M/4	7	1 2 3 4	36/37
	190	186	2.2	52.107.10.□-112M/4 52.108.10.□-112M/4 52.109.10.□-112M/4 52.114.10.□-112M/4	7	1 2 3 4	36/37
	143	240	1.2	52.307.08.□-112M/4 52.308.08.□-112M/4 52.309.08.□-112M/4 52.314.08.□-112M/4	10	1 2 3 4	36/37
	143	243	1.9	52.107.10.□-112M/4 52.108.10.□-112M/4 52.109.10.□-112M/4 52.114.10.□-112M/4	10	1 2 3 4	36/37
	98	344	2.2	52.107.12.□-112M/4 52.108.12.□-112M/4 52.109.12.□-112M/4 52.114.12.□-112M/4	15	1 2 3 4	36/37



### Selection table

<b>P<sub>1</sub></b> Motor power <b>n<sub>2</sub></b> Output speed <b>M<sub>2</sub></b> Output torque <b>i</b> Ratio of the gearbox <b>c<sub>s</sub></b> Operating factor							
<b>P<sub>1</sub></b>	<b>n<sub>2</sub></b> [1/min]	<b>M<sub>2</sub></b> [Nm]	<b>c<sub>s</sub></b>	<b>Type</b> □ Mounting position (see page 16)	<b>i</b>	<b>Design</b>	<b>Dimensions</b> Page
<b>4.0 kW</b>	95	348	1.3	52.107.10.□-112M/4	15	1	36/37
				52.108.10.□-112M/4		2	
				52.109.10.□-112M/4		3	
				52.114.10.□-112M/4		4	
	95	342	0.8	52.307.08.□-112M/4	15	1	36/37
				52.308.08.□-112M/4		2	
				52.309.08.□-112M/4		3	
				52.314.08.□-112M/4		4	
	71	464	1.9	52.107.12.□-112M/4	20	1	36/37
				52.108.12.□-112M/4		2	
52.109.12.□-112M/4				3			
52.114.12.□-112M/4				4			
71	454	1.1	52.107.10.□-112M/4	20	1	36/37	
			52.108.10.□-112M/4		2		
			52.109.10.□-112M/4		3		
			52.114.10.□-112M/4		4		
66	512	1.8	52.107.12.□-132M/6	15	1	36/37	
			52.108.12.□-132M/6		2		
			52.109.12.□-132M/6		3		
			52.114.12.□-132M/6		4		
49	619	1.2	52.107.12.□-112M/4	30	1	36/37	
			52.108.12.□-112M/4		2		
			52.109.12.□-112M/4		3		
			52.114.12.□-112M/4		4		
48	690	1.6	52.107.12.□-132M/6	20	1	36/37	
			52.108.12.□-132M/6		2		
			52.109.12.□-132M/6		3		
			52.114.12.□-132M/6		4		
35	833	1.1	52.107.12.□-112M/4	40	1	36/37	
			52.108.12.□-112M/4		2		
			52.109.12.□-112M/4		3		
			52.114.12.□-112M/4		4		
27	1041	1.0	52.107.12.□-112M/4	53	1	36/37	
			52.108.12.□-112M/4		2		
			52.109.12.□-112M/4		3		
			52.114.12.□-112M/4		4		
<b>5.5 kW</b>	198	245	2.7	52.107.12.□-132S/4	7	1	36/37
				52.108.12.□-132S/4		2	
				52.109.12.□-132S/4		3	
				52.114.12.□-132S/4		4	
	144	339	2.4	52.107.12.□-132S/4	10	1	36/37
				52.108.12.□-132S/4		2	
				52.109.12.□-132S/4		3	
				52.114.12.□-132S/4		4	
	99	470	1.6	52.107.12.□-132S/4	15	1	36/37
52.108.12.□-132S/4				2			
52.109.12.□-132S/4				3			
52.114.12.□-132S/4				4			

Design

1 = Foot-mounted design

2 = Flange-mounted design

3 = Hollow-shaft design

4 = Flange-mounted/Hollow shaft design

# Worm geared motors

## Drive selection

### Selection table

$P_1$ Motor power $n_2$ Output speed $M_2$ Output torque $i$ Ratio of the gearbox $c_s$ Operating factor							
$P_1$	$n_2$ [1/min]	$M_2$ [Nm]	$c_s$	Type □ Mounting position (see page 16)	$i$	Design	Dimensions Page
<b>5.5 kW</b>	72	634	1.4	52.107.12.□-132S/4 52.108.12.□-132S/4 52.109.12.□-132S/4 52.114.12.□-132S/4	20	1 2 3 4	36/37
	49	846	0.9	52.107.12.□-132S/4 52.108.12.□-132S/4 52.109.12.□-132S/4 52.114.12.□-132S/4	30	1 2 3 4	36/37
<b>7.5 kW</b>	200	333	2.0	52.107.12.□-132M/4 52.108.12.□-132M/4 52.109.12.□-132M/4 52.114.12.□-132M/4	7	1 2 3 4	36/37
	145	459	1.7	52.107.12.□-132M/4 52.108.12.□-132M/4 52.109.12.□-132M/4 52.114.12.□-132M/4	10	1 2 3 4	36/37
	100	637	1.2	52.107.12.□-132M/4 52.108.12.□-132M/4 52.109.12.□-132M/4 52.114.12.□-132M/4	15	1 2 3 4	36/37
	72	859	1.0	52.107.12.□-132M/4 52.108.12.□-132M/4 52.109.12.□-132M/4 52.114.12.□-132M/4	20	1 2 3 4	36/37



# Worm geared motors

## Drive selection

### Dimensions

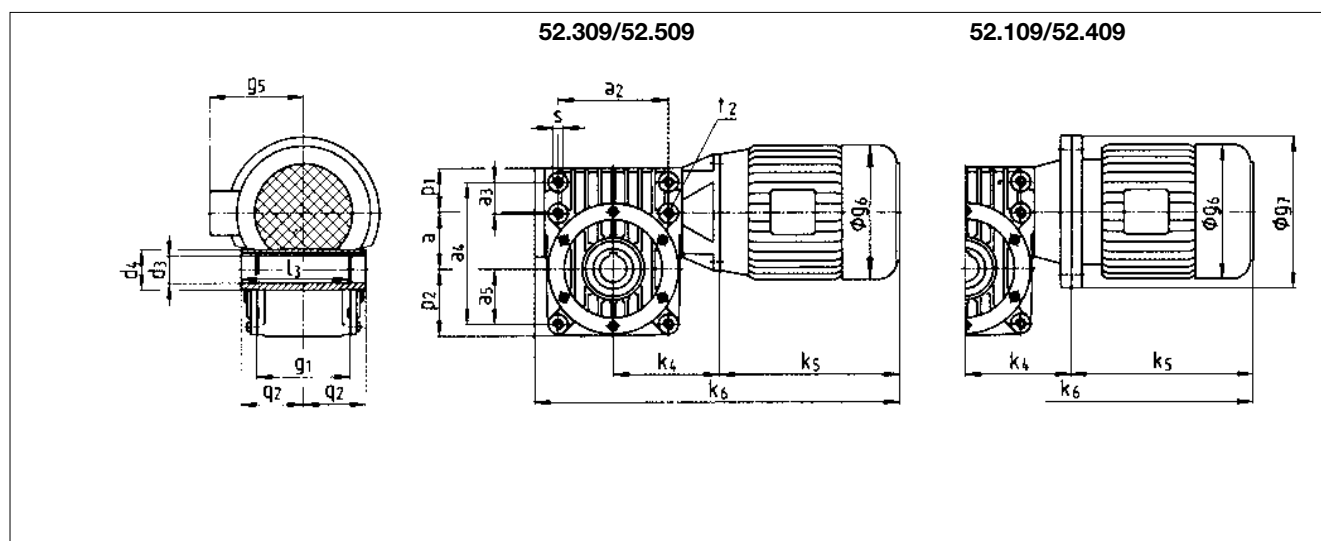
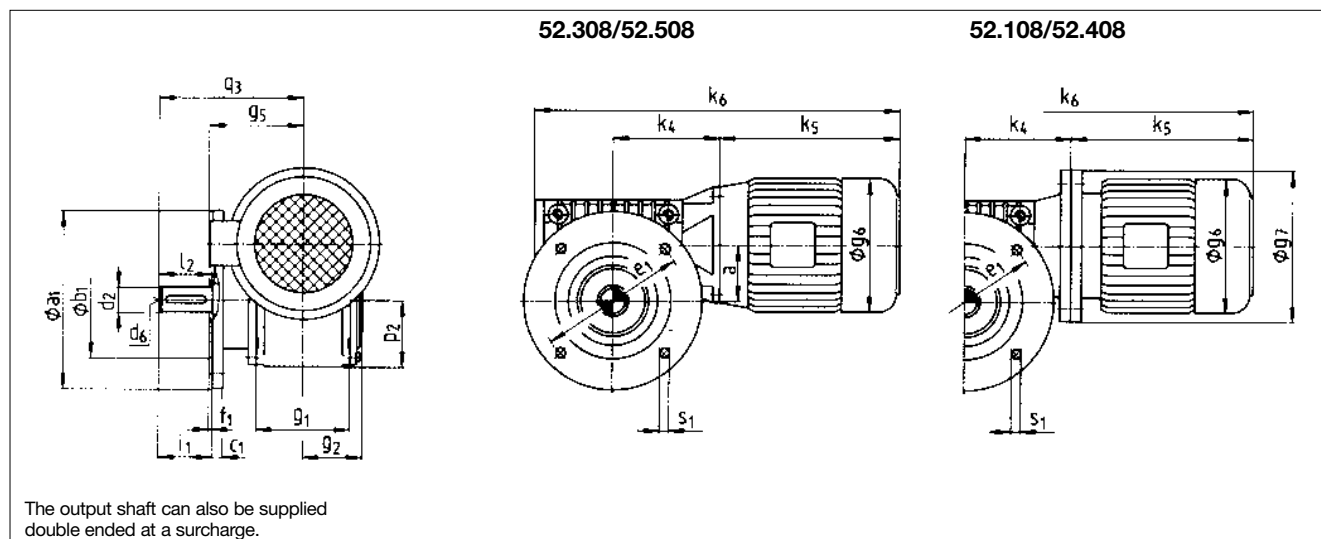
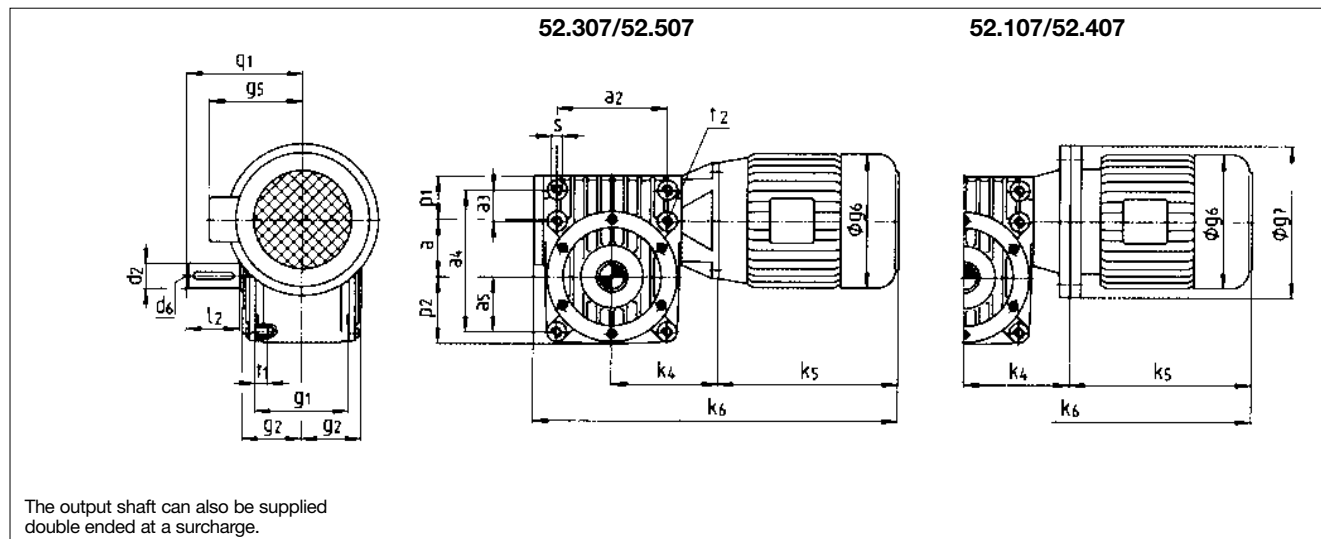

### Dimensions

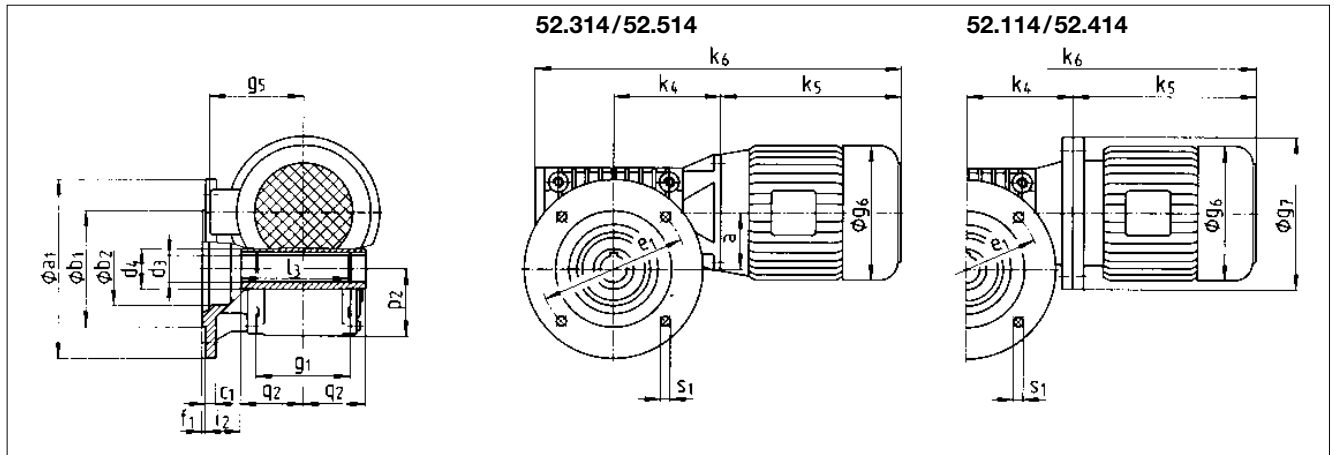

Size	a	a <sub>1</sub> <sup>4)</sup>	a <sub>2</sub>	a <sub>3</sub>	a <sub>4</sub>	a <sub>5</sub>	b <sub>1</sub> <sup>2)</sup> j <sub>7</sub>	b <sub>2</sub>	c <sub>1</sub>	d <sub>2</sub> <sup>1)</sup>	d <sub>3</sub> H <sub>7</sub>	d <sub>4</sub>	d <sub>6</sub>	e <sub>1</sub>	f <sub>1</sub>	g <sub>1</sub>	g <sub>2</sub>	i <sub>1</sub>	i <sub>2</sub>
04	40	120/ <b>140</b>	85	20	105	39	80/ 95	53	8/ 8	19	20	35	M 6	100/115	3/3	76	49	50	29
05	50	140/ <b>160</b>	104	25	129	52	95/110	66	10/10	24	25	45	M 8	115/130	3/3.5	88	59	60	39
06	63	160/ <b>200</b>	124	35	159	62	110/130	82	12/12	28	30	55	M 10	130/165	3.5/3.5	105	67	70	40
08	80	200/ <b>250</b>	148	40	188	74	130/180	99	14/14	38	40	65	M 12	165/215	3.5/4	130	82	80	54
10	100	250/ <b>300</b>	176	50	226	88	180/230	120	16/16	48	50	75	M 16	215/265	4/4	138	87	100	59
12	125	300/ <b>350</b>	224	59	283	112	230/250	150	20/20	55	70	90	M 20	265/300	4/5	174	105	110	68

Size	Motor	g <sub>5</sub> <sup>5)</sup>	g <sub>6</sub> <sup>5)</sup>	g <sub>7</sub>	k <sub>4</sub>	k <sub>5</sub> <sup>5)</sup>	k <sub>6</sub> <sup>5)</sup>	l <sub>2</sub>	l <sub>3</sub>	p <sub>1</sub>	p <sub>2</sub>	q <sub>1</sub>	q <sub>2</sub>	q <sub>3</sub>	s	s <sub>1</sub>	t <sub>1</sub>	t <sub>2</sub>	m <sup>5)</sup> [kg]			
																			52.□07	52.□08	52.□09	52.□14
04	63	112	123	140	119	187	371	50	87	35	51	100	50	122	M 6	6.6/9	10	7.5	13	13	12	13
	71	125	138	160	119	212	396	50	87	35	51	100	50	122	M 6	6.6/9	10	7.5	15	15	14	15
	80	137	156	200	129	233	427	50	87	35	51	100	50	122	M 6	6.6/9	10	7.5	18	18	17	18
05	71	125	138	160	125	212	410	60	104	40	62	120	60	149	M 8	9/9	13	10	19	21	18	20
	80	137	156	200	135	233	441	60	104	40	62	120	60	149	M 8	9/9	13	10	22	24	21	23
06	80	137	156	200	120	233	441	70	122	50	75	140	70	172	M 10	9/11	13	13	30	33	29	32
	90S	147	176	200	120	250	458	70	122	50	75	140	70	172	M 10	9/11	13	13	37	40	36	39
	90L	147	176	200	120	275	483	70	122	50	75	140	70	172	M 10	9/11	13	13	41	44	40	43
08	80	137	156	200	146	233	482	80	148	55	90	165	85	207	M 10	11/14	19	16	42	48	41	47
	90S	147	176	200	146	250	499	80	148	55	90	165	85	207	M 10	11/14	19	16	50	56	49	55
	90L	147	176	200	146	275	524	80	148	55	90	165	85	207	M 10	11/14	19	16	54	60	53	59
	100	156	198	250	146	306	555	80	148	55	90	165	85	207	M 10	11/14	19	16	57	63	56	62
10 <sup>6)</sup>	112	167	220	250	146	322	571	80	148	55	90	165	85	207	M 10	11/14	19	16	73	79	72	78
	90L	147	176	200	153	275	546	100	154	65	110	190	90	234	M 12	14/14	18	18	65	74	68	72
	100	156	198	250	163	306	587	100	154	65	110	190	90	234	M 12	14/14	18	18	68	77	71	75
12 <sup>6)</sup>	112	167	220	250	163	322	603	100	154	65	110	190	90	234	M 12	14/14	18	18	84	93	87	91
	100	156	198	250	195	306	647	110	187	72	141	218	107.5	272	M 16	14/18	23	23	115	122	110	119
	112	167	220	250	195	322	663	110	187	72	141	218	107.5	272	M 16	14/18	23	23	131	138	126	135
	132S	195	260	300	203	363	712	110	187	72	141	218	107.5	272	M 16	14/18	23	23	150	157	145	154
132M	195	260	300	203	401	750	110	187	72	141	218	107.5	272	M 16	14/18	23	23	161	168	156	165	

1) ISO tolerance up to  $\varnothing 50 \text{ mm} = k6$   
over  $\varnothing 50 \text{ mm} = m6$

2) ISO tolerance h7 for b1 over 230 mm

4) Bold print = standard

5) Deviations in motor dimensions possible

6) Sizes 10 and 12 not available as type 52.307/308/309/314

Keys to DIN 6885/1

For motor dimensions see page 50

For brake motors, see the different dimensions and weights according to page 10.

Dimensions in [mm]

# Worm geared motors

## Drive selection

### Options

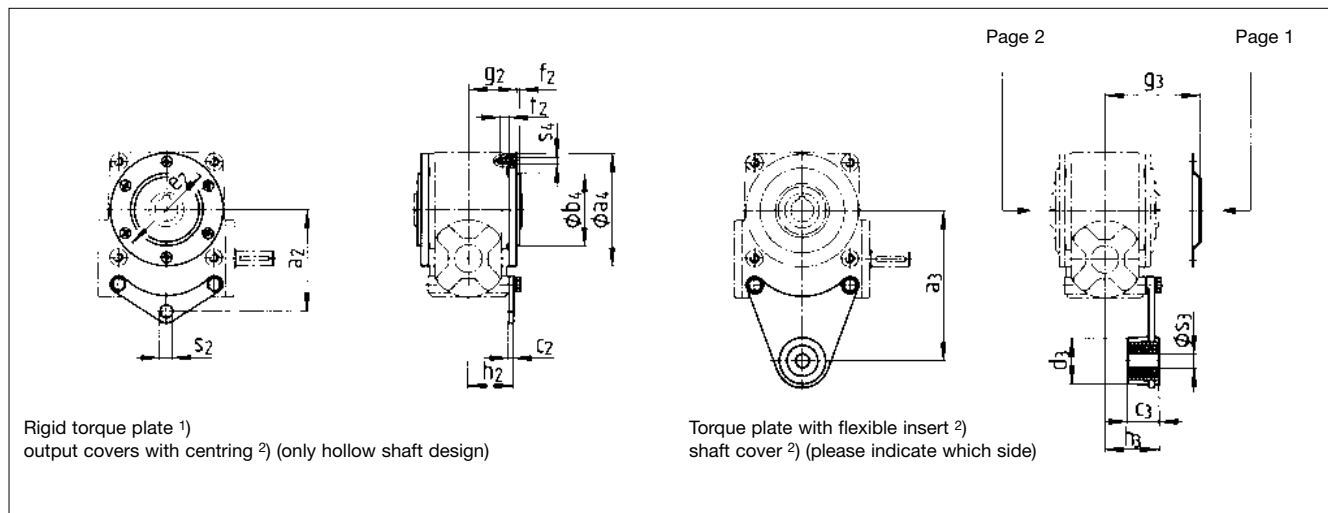
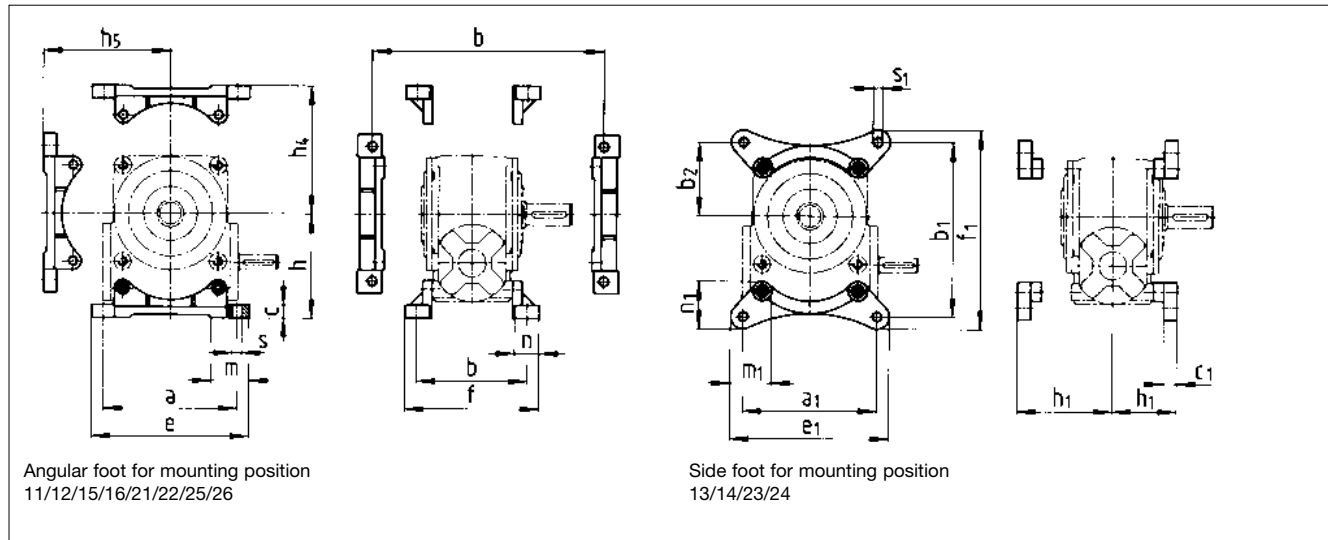

Size	a	a <sub>1</sub>	a <sub>2</sub>	a <sub>3</sub>	a <sub>4</sub>	b	b <sub>1</sub>	b <sub>2</sub>	b <sub>4</sub> j7	c	c <sup>1</sup>	c <sub>2</sub>	c <sub>3</sub>	d <sub>3</sub>	e	e <sub>1</sub>	e <sub>2</sub>
04	118	118	96	130	99	98	157	65	62	11	14	5	41	60	140	142	85
05	152	152	107	155	115	114	191	83	75	14	14	6	41	60	180	178	100
06	174	174	132	195	148	136	225	95	94	17	17	6	41	60	205	206	128
08	212	212	154	220	177	166	268	114	130	19	19	6	46	70	245	248	158
10	240	240	188	275	215	194	310	130	154	22	22	6	46	70	280	284	195
12	300	300	226	339	278	235	375	158	215	25	25	6	70	85	350	350	252

Size	f	f <sub>1</sub>	f <sub>2</sub>	g <sub>2</sub>	g <sub>3</sub>	h	h <sub>1</sub>	h <sub>2</sub>	h <sub>3</sub>	h <sub>4</sub>	h <sub>5</sub>	m	m <sub>1</sub>	n	n <sub>1</sub>	s	s <sub>1</sub>	s <sub>2</sub>	s <sub>3</sub>	s <sub>4</sub>	t <sub>2</sub>
04	122	181	2.5	45.5	57	94	64	43	50	67	71	35	36	21	46	10	10	10.5	18	M 6	8
05	146	217	3	54	69	108	70	50	60	83	83	44	51	27	54	10	10	12.5	18	M 6	11
06	175	257	2	62.5	79	135	83	59	70	100	100	48	54	32	62	12	12	16.5	18	M 6	12
08	200	304	2.5	77	95	161	98	71	85	121	121	58	65	32	73	14	14	16.5	25	M 8	15
10	234	354	2.8	83.7	99	200	109	75	90	150	150	63	67	40	77	18	18	20.5	25	M10	15
12	286	425	3	99.5	120	245	127	93	108	186	186	67	79	48	87	22	22	20.5	30	M12	22

<sup>1)</sup> no surcharge    <sup>2)</sup> surcharge    Dimensions in [mm]

# ***Worm gearboxes***

## ***Product information***

Illustrations	40
Type code	41
Order information	41

## ***Technical data***

Mounting positions	42
Permissible radial forces input	43

## ***Selection worm geared motors***

Selection	44
-----------	----

## ***Drive selection***

Selection tables	46
Dimensions	48
Options gearbox (see chapter geared motors)	38

# Worm gearboxes

## Product information

### Illustrations





### Type code

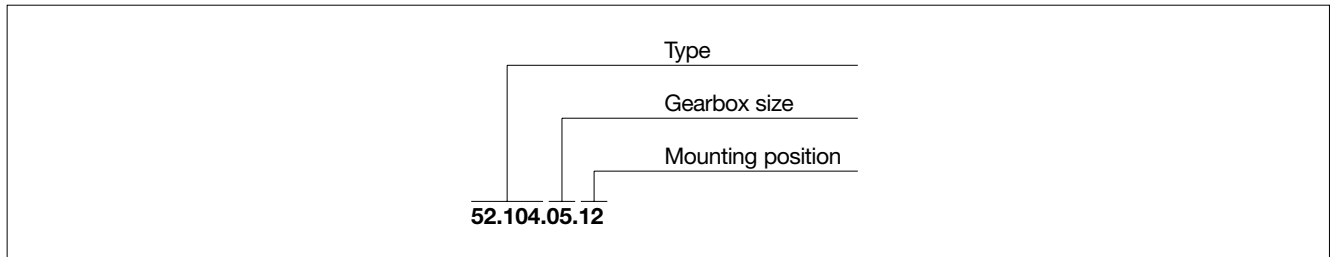

### Type

Design on output side	Type Worm gearboxes
Foot mounted design	52.104
Flange mounted design	52.105
Hollow shaft design	52.106
Flange/Hollow shaft design	52.113

### Gearbox size

04, 05, 06, 08, 10, 12

### Order information

- Complete type code
- Ratio
- Mounting position
- Flange design: Output flange diameter
- Hollow shaft design: hollow shaft bore
- Gearbox design with motor adapter: size of the motor flange
- Gearbox options

# Worm gearboxes

## Technical data

### Mounting positions

with output shaft end

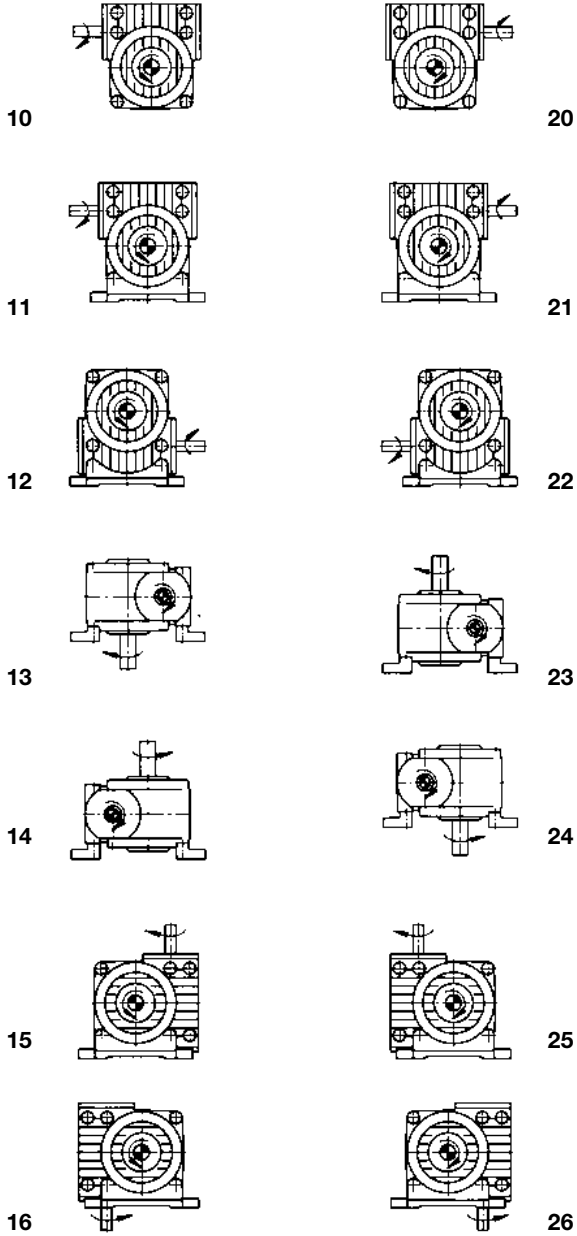

with output flange



with hollow shaft

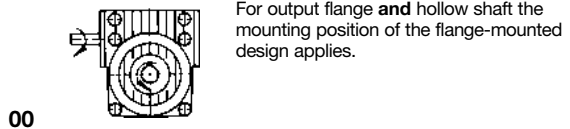

### Permissible radial forces input

$$F_{rperm} = Fr \cdot fw$$

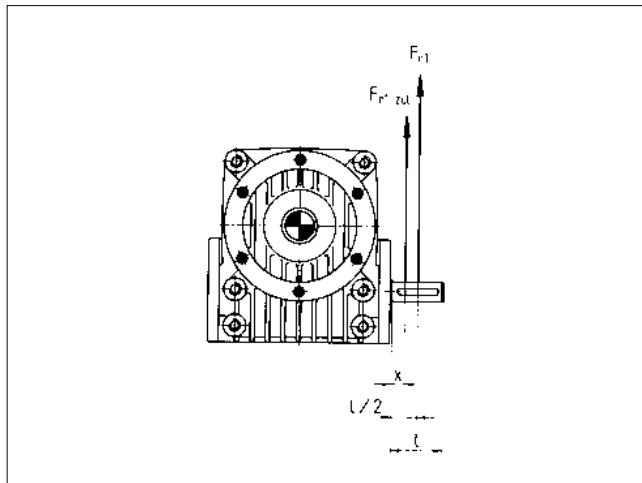

x/l	0	0.2	0.4	0.6	0.8	1
fw	1.2	1.1	1.04	0.9	0.77	0.65

Size	04	05	06	08	10	12	04	05	06	08	10	12	04	05	06	08	10	12
<b>Radial force <math>Fr_1</math> [kN]</b>																		
<b>i</b>	<b><math>n_1 = 2800</math> 1/min</b>						<b><math>n_1 = 1400</math> 1/min</b>						<b><math>n_1 = 930</math> 1/min</b>					
5	1.00	1.90	2.75	3.9	5.5	8.2	1.05	1.90	2.75	3.8	5.5	8.2	1.00	1.80	2.75	3.8	5.5	8.2
7	1.00	1.90	2.75	3.9	5.6	8.2	1.05	1.90	2.75	3.9	5.5	8.2	0.85	1.90	2.75	3.8	5.5	8.2
10	0.80	1.55	2.65	3.9	5.6	8.2	0.80	1.90	2.40	3.7	5.5	8.0	1.05	1.75	2.20	3.5	5.5	7.4
13	1.10	1.95	1.45	3.9	4.0	4.6	1.10	1.95	1.25	3.9	3.2	3.7	1.10	1.95	1.10	3.9	3.0	3.2
15	1.00	1.70	2.75	3.9	5.6	8.2	1.00	1.80	2.75	3.9	5.6	8.2	0.50	1.75	2.75	3.9	5.6	8.2
20	0.65	1.40	2.75	3.9	5.6	8.2	0.50	1.70	2.50	3.7	5.6	8.1	0.50	1.35	2.30	3.6	5.5	7.5
26	1.10	1.95	1.55	3.9	4.0	4.6	1.10	1.95	1.30	3.9	3.3	3.8	1.10	1.95	1.05	3.9	3.1	3.4
30	0.80	1.30	2.75	3.9	5.6	8.2	0.65	1.80	2.75	3.9	5.6	8.2	0.50	1.55	2.75	3.9	5.6	8.2
40	0.50	1.25	2.75	3.9	5.6	8.2	0.50	1.50	2.50	3.7	5.6	8.1	0.50	1.25	2.30	3.6	5.5	7.5
53	0.80	1.25	1.55	3.9	4.0	4.6	1.10	1.95	1.30	3.9	3.3	3.8	1.10	1.95	1.05	3.9	3.1	3.4
60	0.75	1.25	2.75	3.9	5.6	8.2	1.10	1.95	2.75	3.9	5.6	8.2	1.10	1.95	2.75	3.9	5.6	8.2
<b>i</b>	<b><math>n_1 = 700</math> 1/min</b>						<b><math>n_1 = 500</math> 1/min</b>						<b><math>n_1 = 150</math> 1/min</b>					
5	1.00	1.85	2.75	3.8	5.5	8.2	1.00	1.80	2.75	3.8	5.5	8.1	1.00	1.80	2.65	3.7	5.1	7.7
7	0.95	1.75	2.75	3.8	5.5	8.2	0.95	1.30	2.75	3.8	5.5	8.2	1.00	1.80	2.70	3.8	5.3	8.0
10	1.05	1.35	2.00	3.2	5.0	6.8	1.05	1.60	1.75	2.9	4.5	5.9	1.05	1.60	1.70	2.4	2.7	3.3
13	1.10	1.95	1.10	3.9	2.5	2.6	1.10	1.95	1.10	3.9	2.5	2.6	1.10	1.95	1.10	3.9	2.5	2.6
15	0.50	1.35	2.75	3.9	5.5	8.2	1.00	1.25	2.75	3.9	5.5	8.2	1.00	1.85	2.75	3.8	5.5	8.2
20	1.00	1.25	2.10	3.4	5.2	6.8	1.05	1.55	1.90	3.0	4.7	6.2	1.00	1.60	1.80	2.6	3.2	4.3
26	1.10	1.95	0.95	3.9	2.7	2.8	1.10	1.95	0.95	3.9	2.1	2.2	1.10	1.95	0.90	3.9	2.1	2.2
30	0.50	1.25	2.75	3.9	5.6	8.2	1.00	1.25	2.75	3.9	5.6	8.2	1.00	1.85	2.75	3.9	5.5	8.2
40	0.75	1.25	2.10	3.4	5.2	7.0	1.05	1.35	2.00	3.1	4.8	6.5	1.05	1.60	1.85	2.6	3.4	4.9
53	1.10	1.95	0.95	3.9	2.8	2.9	1.10	1.95	0.95	3.9	2.2	2.3	1.10	1.95	0.80	3.9	2.0	2.0
60	1.10	1.95	2.75	3.9	5.6	8.2	1.10	1.95	2.75	3.9	5.6	8.2	1.10	1.95	2.75	3.9	5.6	8.2

# Worm gearboxes

## Selection

### Selection

A worm gearbox can be selected according to the rated power (P) or the torque required by the machine (M).

#### Selection according to the torque:

$$M = \frac{9550 \cdot P}{n_2}$$

$M$  = Required torque at the machine in Nm

$P$  = Required power at the machine in kW

$n_2$  = Speed at the machine in 1/min

= Output speed of the gearbox

For the desired input speed  $n_1$  and ratio  $i$ , the gearbox output torque  $M_2$  (selection table) must at least as great as the greater of the two torques  $M_m$  or  $M_w$ .

$$M_2 \geq M_m = M \cdot k_A$$
$$M_2 \geq M_w = M \cdot k_T$$

$M_2$  = Output torque according to selection table

$M_m$  = Calculated mechanical output torque in Nm

$M_w$  = Calculated thermic output torque in Nm

$k_A$  = Factor according to table page 18

$k_T$  = Factor according to table page 18

## Selection

### Selection according to the required power:

The power (P) required by the machine is calculated using the following equations:

$$P_m = P \cdot k_A$$
$$P_w = P \cdot k_T$$

For the greater of the two powers  $P_m$  or  $P_w$ , check if:

$$P_1 \geq \frac{P_m}{\eta}$$
$$P_1 \geq \frac{P_w}{\eta}$$

$P_m$  = calculated mechanical output power in kW

$P_w$  = calculated thermic power in kW

$P_1$  = Input power in kW

$k_A$  = Factor according to table page 18

$k_T$  = Factor according to table page 18

Considering the output speed  $n_1$  and the desired ratio  $i$ , the value  $\eta$  can be obtained from the selection table.

# Worm gearboxes

## Drive selection

### Selection table

$P_1$  = Input power  
 $M_2$  = Output torque  
 $\eta$  = Efficiency  
 $n_1$  = Input speed  
 $i$  = Ratio of the gearbox

$n_1$	2800 1/min						1400 1/min						930 1/min					
Size	04	05	06	08	10	12	04	05	06	08	10	12	04	05	06	08	10	12
$i$	$P_1$ [kW] $M_2$ [Nm] $\eta$ [%]																	
5	2.81 43 93	3.97 61 93	6.02 92 93	8.70 138 93	12.59 201 94	21.8 338 94	1.77 53 91	2.62 79 91	4.51 138 93	7.40 236 94	11.39 366 94	18.9 593 95	1.47 66 90	2.18 99 92	3.54 162 92	5.50 262 93	8.75 422 94	16.6 784 95
7	2.11 47 90	3.02 68 91	4.60 103 91	6.75 157 91	9.77 229 92	16.6 380 93	1.34 59 89	1.97 87 89	3.39 152 91	5.63 263 91	8.84 419 93	14.4 665 93	1.12 72 88	1.65 109 89	2.67 178 90	4.19 293 91	6.66 472 92	12.4 862 93
10	1.89 57 88	2.64 77 89	4.18 125 90	6.03 185 90	8.80 272 91	14.7 457 91	1.13 67 87	1.69 96 88	2.91 172 89	4.80 295 90	7.55 471 91	12.7 805 93	0.75 66 86	1.42 120 87	2.29 201 88	3.58 327 89	5.67 528 91	10.3 976 92
13*)	0.90 34 85	1.45 57 87	3.64 139 88	5.42 218 89	7.94 316 90	13.3 536 90	0.45 34 84	0.74 56 83	2.49 188 87	4.08 326 88	6.53 521 90	11.0 892 91	0.30 33 81	0.49 55 83	1.85 207 85	3.03 360 87	4.90 583 89	8.88 1077 91
15	1.23 50 82	1.78 74 84	2.71 113 84	4.00 174 85	5.77 253 86	9.73 420 87	0.79 63 81	1.16 94 82	1.99 164 83	3.29 288 86	5.12 458 87	8.38 736 89	0.65 76 78	0.98 118 81	1.58 193 82	2.47 321 84	3.88 516 86	7.12 940 89
20	0.97 54 81	1.55 82 82	2.49 137 83	3.58 203 83	5.25 302 84	8.70 508 86	0.66 71 79	1.01 104 79	1.73 186 81	2.83 320 83	4.44 516 85	7.42 883 87	0.52 82 77	0.85 129 78	1.37 218 79	2.12 356 82	3.36 580 84	6.03 1072 87
26*)	0.64 44 78	1.07 76 79	2.16 150 80	3.25 240 82	4.73 347 83	7.87 588 84	0.33 44 74	0.55 75 75	1.50 203 78	2.44 355 80	3.85 567 83	6.47 979 85	0.23 43 70	0.37 74 74	1.19 237 76	1.83 392 79	2.91 635 82	5.25 1184 84
30	0.65 46 71	0.96 69 73	1.51 109 73	2.35 179 74	3.10 233 73	5.19 396 77	0.47 64 69	0.69 96 70	1.18 168 72	1.92 295 75	2.70 419 76	4.78 759 80	0.38 76 67	0.59 121 69	0.95 197 70	1.46 329 73	2.06 472 74	4.05 966 80
40	0.52 48 69	0.86 77 69	1.37 129 71	2.13 208 72	3.10 312 74	4.66 475 75	0.39 70 66	0.62 106 66	1.05 191 68	1.68 328 72	2.60 531 75	4.26 906 78	0.31 80 63	0.52 129 64	0.84 223 66	1.28 365 69	1.98 597 73	3.49 1100 77
53	0.43 48 63	0.64 75 65	1.22 142 67	1.91 239 69	2.82 355 71	4.20 541 73	0.23 48 59	0.38 85 62	0.93 208 64	1.48 363 68	2.29 581 72	3.78 1006 75	0.16 48 56	0.27 84 57	0.75 243 62	1.13 402 65	1.75 652 70	3.09 1218 74
60	0.39 46 56	0.55 65 55	0.96 115 58	1.42 179 60	2.10 275 62	3.01 400 63	0.21 46 51	0.36 78 51	0.74 172 56	1.19 300 60	1.80 487 64	2.92 837 68	0.15 45 48	0.25 78 49	0.57 189 53	0.91 334 58	1.39 548 62	2.41 1017 66

\*) The ratios 13 and 26 are only available for gearboxes with free input shaft (type 52.104/105/106/113)

### Selection table

$P_1$ = Input power $M_2$ = Output torque $\eta$ = Efficiency $n_1$ = Input speed $i$ = Ratio of the gearbox																		
$n_1$	700 1/min						500 1/min						150 1/min					
Size	04	05	06	08	10	12	04	05	06	08	10	12	04	05	06	08	10	12
$i$	$P_1$ [kW] $M_2$ [Nm] $\eta$ [%]																	
5	1.13 67 90	1.93 115 90	3.15 189 91	4.91 310 93	7.89 504 94	15.06 942 95	0.82 66 87	1.67 138 90	2.73 228 90	4.30 376 92	6.95 618 93	13.34 1163 94	0.25 63 82	0.52 138 86	1.13 298 86	2.19 610 88	4.32 1234 90	7.08 2000 92
7	0.91 77 86	1.46 127 88	2.38 209 89	3.76 346 90	6.02 564 92	11.24 1035 93	0.66 77 84	1.27 152 86	2.08 251 87	3.29 421 89	5.32 692 91	9.97 1279 93	0.21 74 76	0.42 158 82	0.90 339 82	1.75 700 84	3.35 1387 87	5.10 2100 89
10	0.57 66 84	1.26 140 86	2.03 234 87	3.20 386 88	5.11 628 90	9.34 1168 92	0.41 65 83	0.95 145 84	1.77 281 85	2.80 468 88	4.51 768 89	8.26 1437 91	0.13 62 76	0.30 142 78	0.58 285 79	1.17 605 81	2.23 1194 84	3.98 2200 87
13*)	0.23 33 80	0.37 55 82	1.40 205 84	2.52 393 86	4.41 692 88	8.02 1285 90	0.17 32 77	0.27 54 79	1.01 203 83	1.81 389 85	3.24 704 88	5.81 1291 90	0.05 31 72	0.08 51 72	0.31 192 76	0.56 370 78	1.00 676 82	1.79 1248 84
15	0.54 83 78	0.88 138 79	1.41 226 81	2.22 379 83	3.52 617 86	6.48 1130 88	0.41 85 75	0.74 158 77	1.25 273 79	1.97 461 82	3.13 758 84	5.78 1396 87	0.14 83 66	0.25 160 69	0.46 300 71	0.99 700 74	1.88 1400 78	2.98 2250 82
20	0.40 83 76	0.73 145 77	1.23 255 78	1.91 420 81	3.04 691 83	5.48 1285 86	0.30 82 72	0.58 156 74	1.06 300 76	1.69 510 79	2.70 847 82	4.88 1582 85	0.10 82 65	0.20 155 65	0.36 302 68	0.72 647 71	1.35 1283 75	2.25 2250 79
26*)	0.17 43 69	0.29 74 70	1.01 262 75	1.64 459 77	2.63 755 81	4.76 1414 84	0.13 42 67	0.21 73 68	0.75 262 72	1.20 460 76	2.34 923 79	4.22 1729 83	0.04 41 59	0.07 69 61	0.25 252 62	0.41 456 66	0.76 896 71	1.35 1679 75
30	0.33 84 64	0.54 141 66	0.86 232 68	1.32 390 72	1.88 563 73	3.71 1161 79	0.25 85 61	0.45 158 63	0.77 280 66	1.18 475 70	1.69 691 71	3.33 1436 78	0.09 85 51	0.16 160 54	0.34 350 56	0.61 700 60	1.12 1328 62	1.74 2250 70
40	0.26 85 60	0.45 144 62	0.76 262 65	1.16 430 68	1.81 711 72	3.19 1319 76	0.19 84 58	0.37 159 59	0.65 300 62	1.04 523 66	1.62 871 70	2.87 1625 74	0.07 85 49	0.13 159 49	0.24 300 50	0.47 658 55	0.85 1310 61	1.35 2250 65
53	0.13 48 54	0.21 84 55	0.64 267 60	1.01 466 64	1.60 775 68	2.82 1455 73	0.09 47 51	0.15 83 53	0.48 266 57	0.75 466 61	1.44 948 66	2.54 1787 71	0.03 50 43	0.06 85 45	0.18 270 47	0.27 469 51	0.53 980 56	0.95 1909 61
60	0.12 45 46	0.20 78 46	0.45 189 50	0.84 394 55	1.28 653 60	2.21 1218 65	0.09 45 43	0.15 78 44	0.34 188 47	0.67 422 53	1.16 800 58	2.01 1501 63	0.03 46 35	0.06 78 34	0.13 190 37	0.26 429 42	0.46 849 47	0.82 1709 53

\*) The ratios 13 and 26 are only available for gearboxes with free input shaft (type 52.104/105/106/113)

# Worm gearboxes

## Drive selection

### Dimensions

52.104

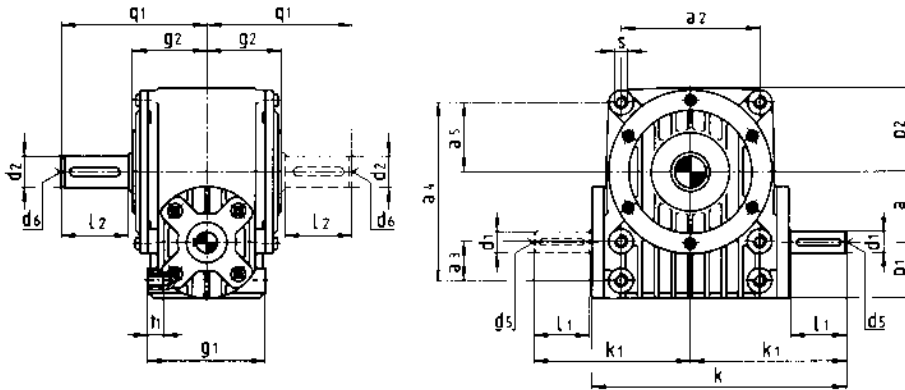

Input and output shaft can also be supplied double ended at a surcharge.

52.105

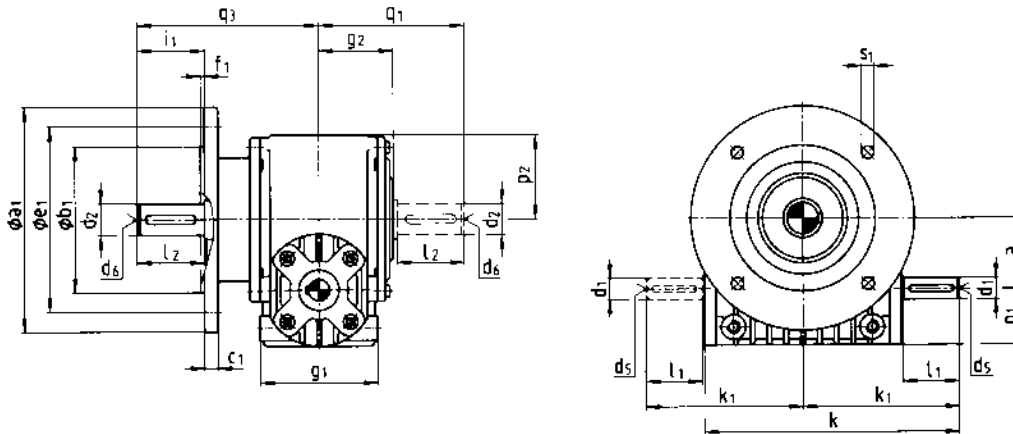

Input and output shaft can also be supplied double ended at a surcharge.

52.106

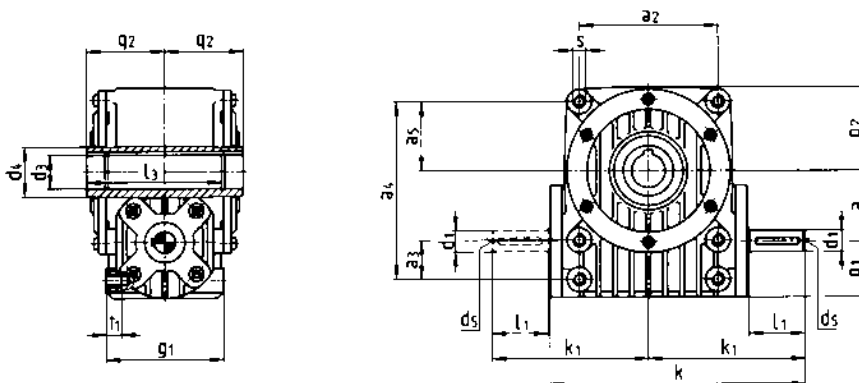

Input shaft can also be supplied double ended at a surcharge.

Dimensions for gearbox feet, torque plate or output cover with centring see under options on page 38.



### Dimensions

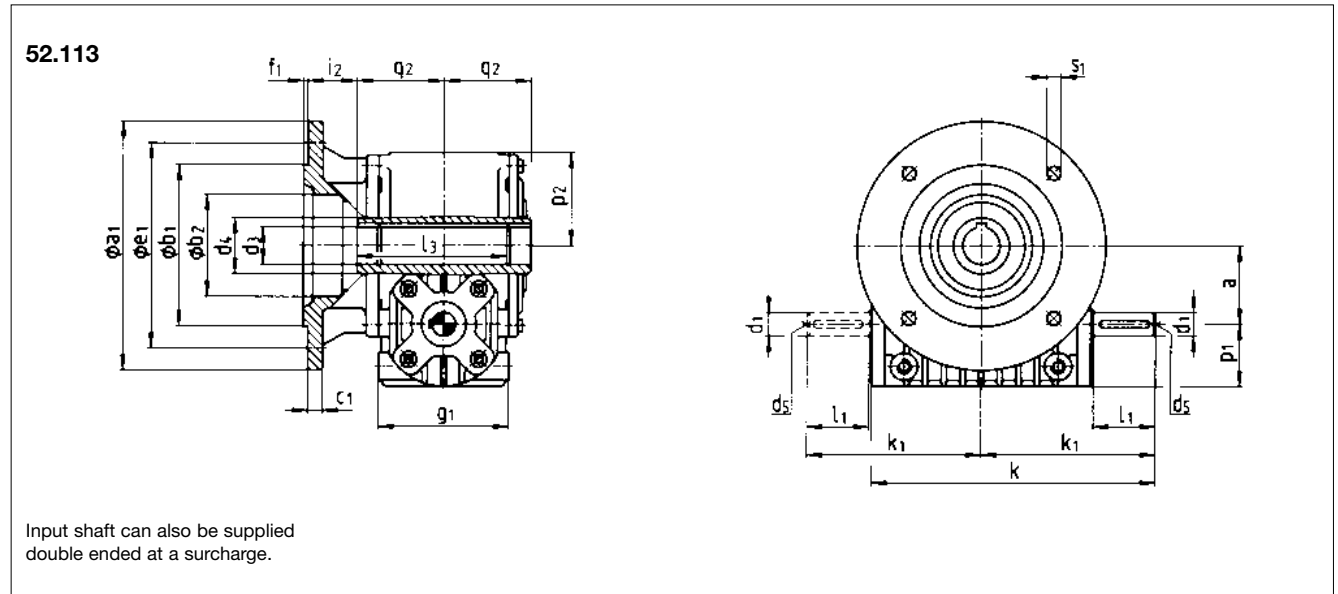

Size	a	a <sub>1</sub> <sup>3)</sup>	a <sub>2</sub>	a <sub>3</sub>	a <sub>4</sub>	a <sub>5</sub>	b <sub>1</sub> <sup>2)</sup> j7	b <sub>2</sub>	c <sub>1</sub>	d <sub>1</sub> k6	d <sub>2</sub> <sup>1)</sup>	d <sub>3</sub> H7	d <sub>4</sub>	d <sub>5</sub>	d <sub>6</sub>	e <sub>1</sub>	f <sub>1</sub>	g <sub>1</sub>
04	40	120/140	85	20	105	39	80/ 95	53	8	14	19	20	35	M 6	M 6	100/115	3 /3	76
05	50	140/160	104	25	129	52	95/110	66	10	19	24	25	45	M 6	M 8	115/130	3 /3.5	88
06	63	160/200	124	35	159	62	110/130	82	12	19	28	30	55	M 6	M 10	130/165	3.5/3.5	105
08	80	200/250	148	40	188	74	130/180	99	14	24	38	40	65	M 8	M 12	165/215	3.5/4	130
10	100	250/300	176	50	226	88	180/230	120	16	28	48	50	75	M 10	M 16	215/265	4 /4	138
12	125	300/350	224	59	283	112	230/250	150	20	38	55	70	90	M 12	M 20	265/300	4 /5	174

Size	g <sub>2</sub>	i <sub>1</sub>	i <sub>2</sub>	k	k <sub>1</sub>	l <sub>1</sub>	l <sub>2</sub>	l <sub>3</sub>	p <sub>1</sub>	p <sub>2</sub>	q <sub>1</sub>	q <sub>2</sub>	q <sub>3</sub>	s	s <sub>1</sub>	t <sub>1</sub>	m [kg]			
																	52.104	52.105	52.106	52.113
04	49	50	29	172	107	40	50	87	35	51	100	50	122	M 6	6.6/ 9	10	5.2	6.5	6	6.5
05	59	60	39	198	125	50	60	104	40	62	120	60	149	M 8	9 / 9	13	9.5	12	9	12
06	67	70	40	228	140	50	70	122	50	75	140	70	172	M 10	9 /11	13	16	20	16	20
08	82	80	54	268	165	60	80	148	55	90	165	85	207	M 10	11 /14	19	28	34	27	34
10	87	100	59	308	190	70	100	154	65	110	190	90	234	M 12	14 /14	18	39	48	42	48
12	105	110	68	385	239	90	110	187	72	141	218	107.5	272	M 16	14 /18	23	75	82	80	82

1) ISO tolerance up to Ø 50 mm = k6  
over Ø 50 mm = m6

2) ISO tolerance h7 for b<sub>1</sub> over 230 mm

3) Bold print = standard

Keys to DIN 6885/1

Dimensions in [mm]

# Worm gearboxes

## Drive selection

### Dimensions

52.107/108/109/114  
52.407/408/409/414

52.307/308/309/314  
52.507/508/509/514

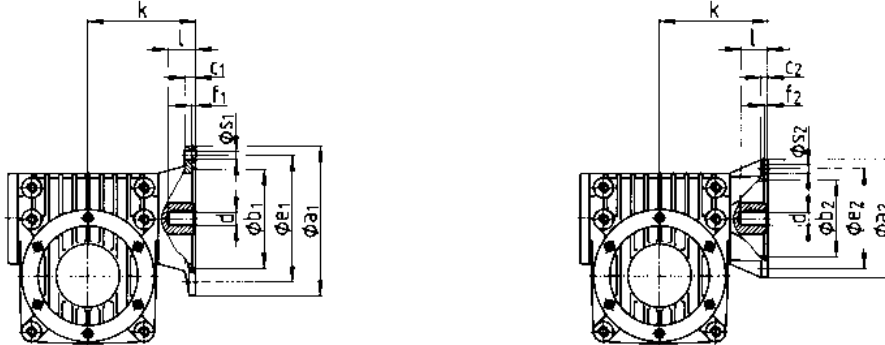

Size	Motor	a <sub>1</sub>	a <sub>2</sub>	b <sub>1</sub> H8	b <sub>2</sub> H8	c <sub>1</sub>	c <sub>2</sub>	d
04	63	–	90	–	60	–	7	11 H7
	63	140	–	95	–	9	–	11 H7
	71	160	105/140	110	70/ 95	9	7/9	14 H7
	80	200	120/160	130	80/110	12	7/9	19 H7
05	71	160	105/140	110	70/ 95	9	7/9	14 H7
	80	200	120/160	130	80/110	12	7/9	19 H7
06	80	200	140/160	130	95/110	15	10/14	19 E7
	90	200	140/160	130	95/110	15	10/14	24 E7
08	80	200	160	130	110	15	14	19 E7
	90	200	160	130	110	15	14	24 E7
	100/112	250	160/200	180	110/130	18	14/15	28 E7
10	90	200	–	130	–	15	–	24 E7
	100/112	250	–	180	–	18	–	28 E7
12	100/112	250	–	180	–	18	–	28 E7
	132	300	–	230	–	18	–	38 E7

Size	Motor	e <sub>1</sub>	e <sub>2</sub>	f <sub>1</sub>	f <sub>2</sub>	k	l	s <sub>1</sub>	s <sub>2</sub>
04	63	–	75	–	3	114	25	–	5,5
	63	115	–	4	–	119	30	9	–
	71	130	85/115	4	4	119	30	M 8	7/9
	80	165	100/130	4	4	129	40	M 10	7/9
05	71	130	85/115	4	4	125	30	M 8	7/9
	80	165	100/130	4	4	135	40	M 10	7/9
06	80	165	115/130	4	4	120	40	M 10	9
	90	165	115/130	4	4	120	50	M 10	9
08	80	165	130	4	4	146	40	M 10	9
	90	165	130	4	4	146	50	M 10	9
	100/112	215	130/165	5	4	146	60	M 12	9
10	90	165	–	4	–	153	50	M 10	–
	100/112	215	–	5	–	163	60	M 12	–
12	100/112	215	–	5	–	195	60	M 12	–
	132	265	–	5	–	203	80	M 12	–

For other dimensions see "Worm-gearred motors"  
Dimensions in [mm]

# Compact units

## Product information

Illustrations	52
Type code	53
Order information	53

## Technical data

Mounting positions	54
Swivel positions	56
Terminal box positions	56
Position of adjustment units	57
General data of belt variable speed drives	58

## Selection

<b>Selection</b>	
- Determination of the rated point	59
- Determination of the operating factor k	60
- Determination of the effective forces	60

## Drive selection

Selection tables	61
Dimensions	64

### Options for belt variable speed drives

#### Speed-adjustment units

- Angular control	68
- Electrical remote control	68

#### Speed-measuring units

- DC signal generator	70
- Pulse generator	70
- Handwheel indicator	70
- Analog display	70
- Digital display	70

Options for gearboxes (see chapter geared motors) \_ 38

# Compact units

## Product information

### Illustrations

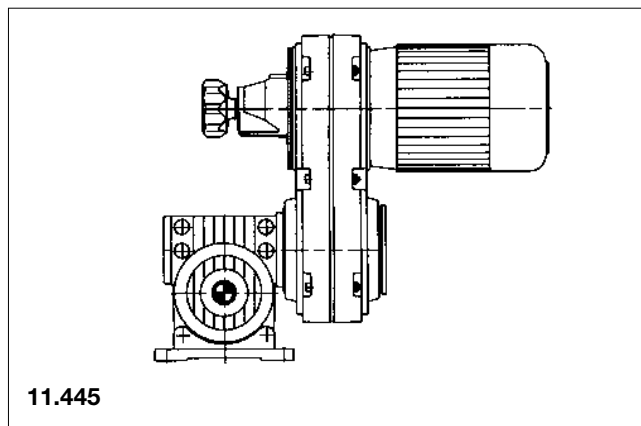
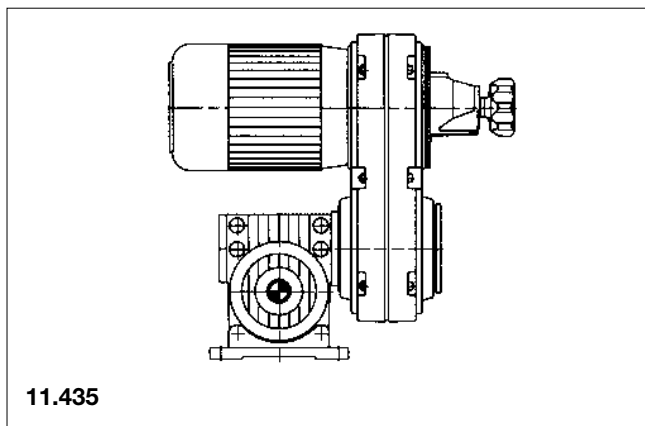

### Type code

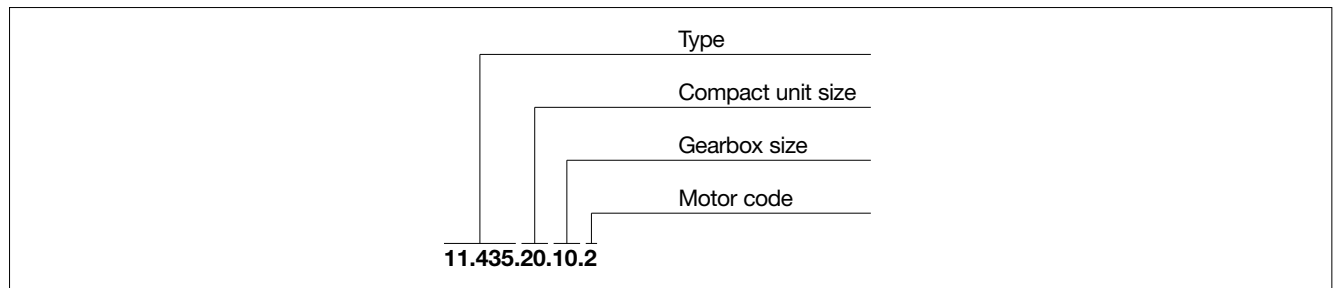

### Type

11.435 Compact unit in U-configuration  
 11.445 Compact unit in Z-configuration

### Compact unit size

10, 13, 16, 20, 25

### Gearbox size

Worm gearboxes 04, 05, 06, 08, 10, 12

### Motor code

Motor code	Compact unit size						
	10	13	16	20	25	31	40
	IEC motor frame size, mounting, flange diameter						
1	71 B14 / 105	71 B5 / 160	80 B14 / 160	90 B14 / 160	100/112 B5 / 250	132 B5 / 300	180 B5 / 350
2		80 B14 / 160	90 B14 / 160	100 B14 / 160	132 B5 / 300	160 M B5 / 350	200 B5 / 400
3		90 B14 / 160	100 B14 / 160	112 B14 / 160	160 B5 / <b>300*</b>	160 L B5 / 350	225 B5 / 450
4						180 B5 / 350	

\* special flange

### Order information

- Complete type code
- Ratio
- Motor power and voltage
- Mounting positions and position of the terminal box
- Flange design: output flange diameter
- Hollow shaft design: hollow shaft bore
- Compact unit options
- Gearbox options
- Motor options

# Compact units

## Technical data

### Mountings

#### Foot-mounted design

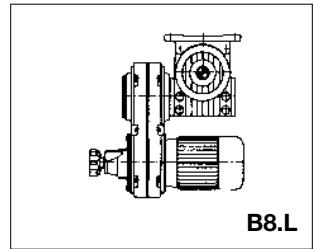
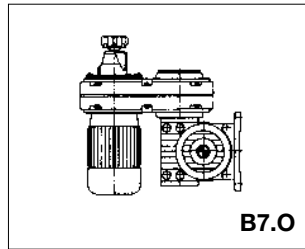
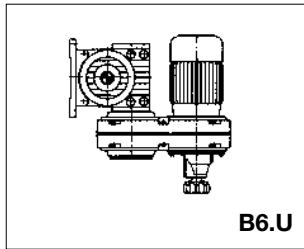
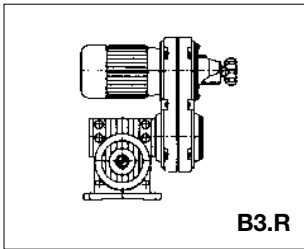
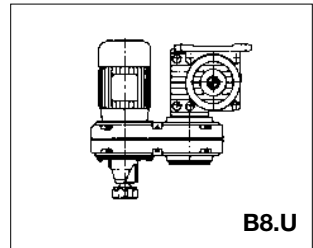
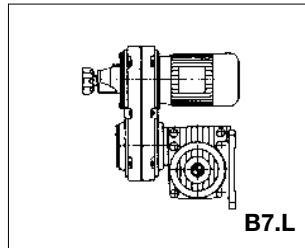
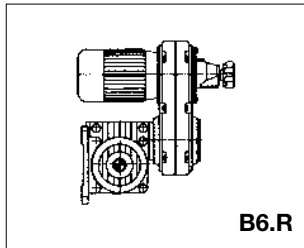
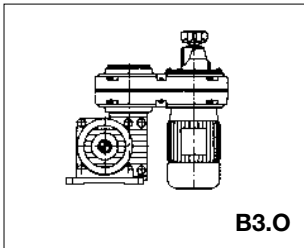
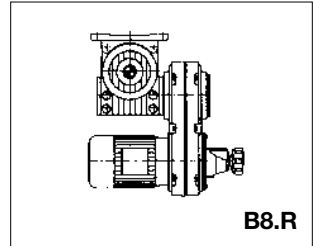
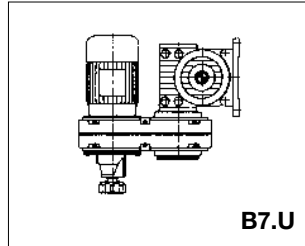
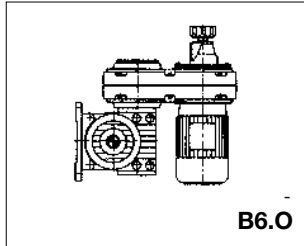
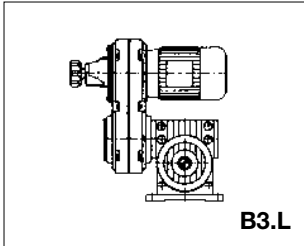

#### Flange-mounted design

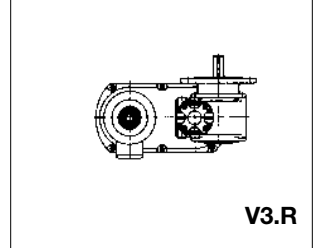
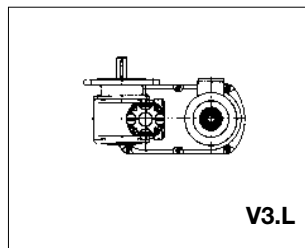
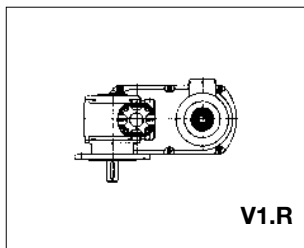
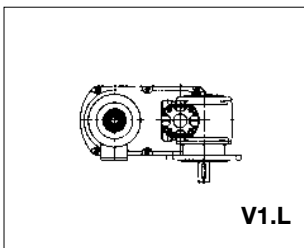
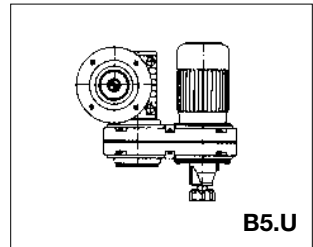
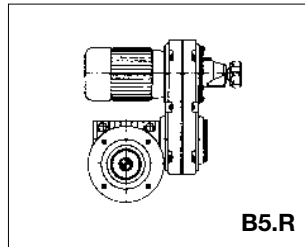
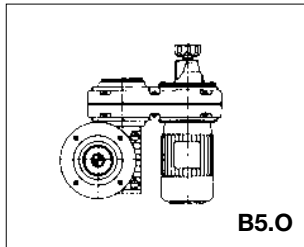
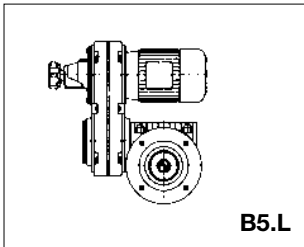
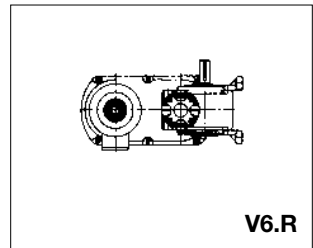
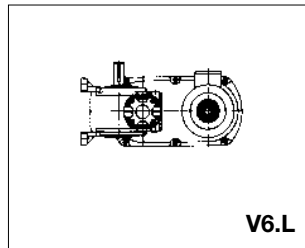
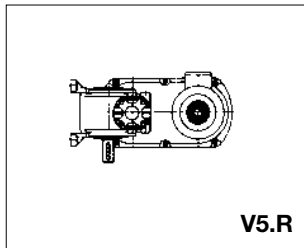
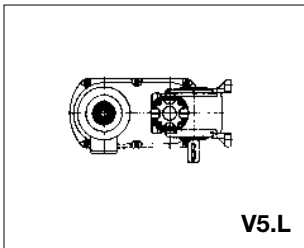

### Mountings

#### Hollow shaft design

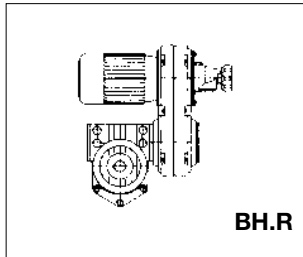

BH.R

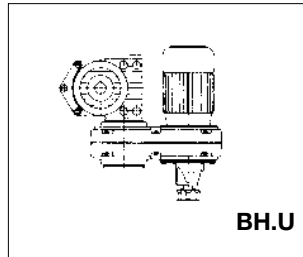

BH.U

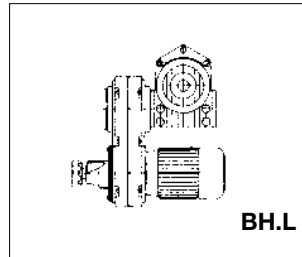

BH.L

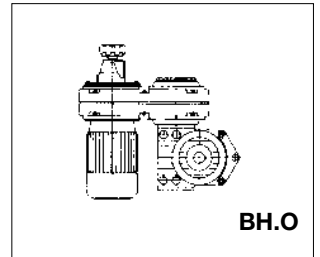

BH.O

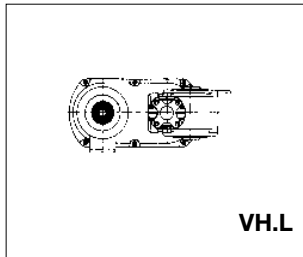

VH.L

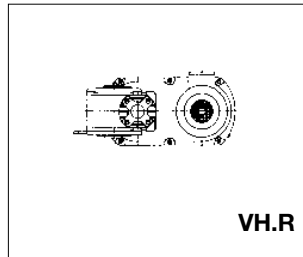

VH.R

#### Flange hollow shaft design

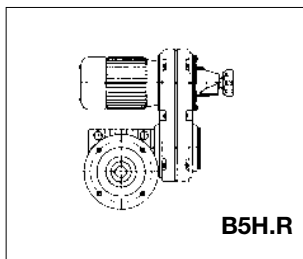

B5H.R

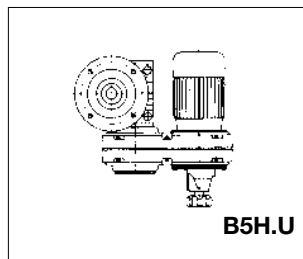

B5H.U

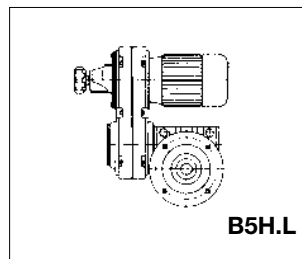

B5H.L

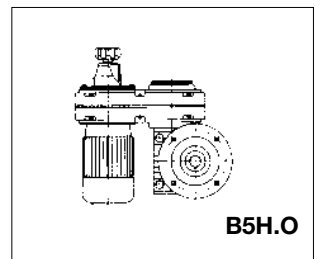

B5H.O

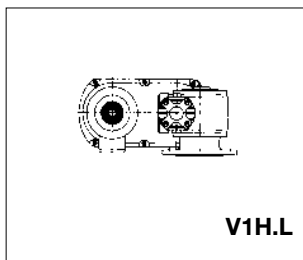

V1H.L

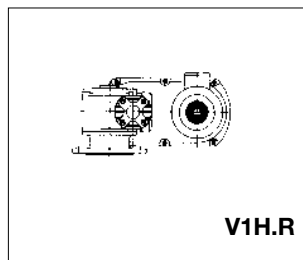

V1H.R

The mounting denominations are also valid for Z-configuration.  
The motor is mounted opposite to the gearbox.

# Compact units

## Technical data

### Swivel positions

### Terminal box positions

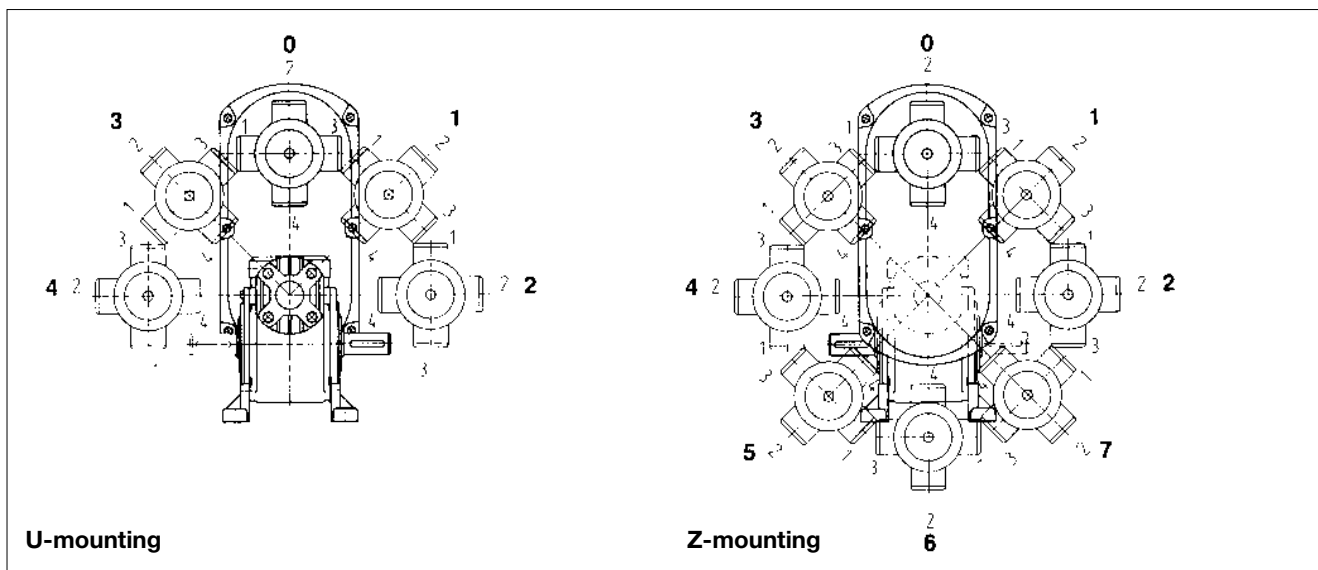

Swivel positions and terminal box positions are fixed with view from the motor fan side.

If no indications of the position of terminal box and swivel position are given, swivel position 0 and terminal box position 1 are supplied.

For swivel position 4 without indication of terminal box position, terminal box position 2 is supplied.

Example:

**V1.L.2** terminal box pos. 3  
swivel position  
mounting

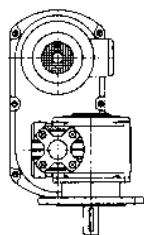

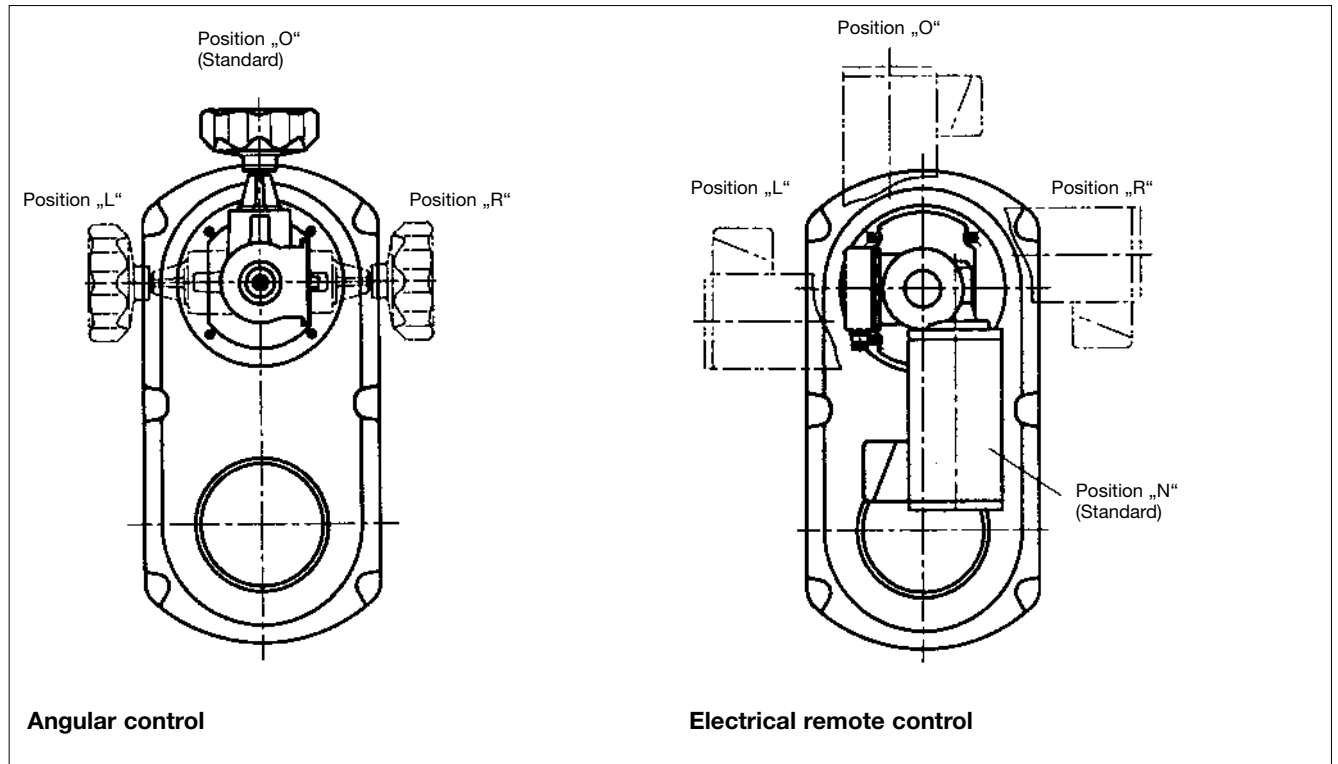

**Position of adjustment units**

**Note** The control position does not depend on the overall mounting.

For U-configuration with speed-measuring units,  
the position N is not possible. Position O is here standard.  
For Z-configuration, the position N is not possible.  
Position R is here standard.

# Compact units

## Technical data

### General data of belt variable speed drives

#### Features

- Hub: coated, polygon profile
- Variable speed pulleys: self-centering, prestress by helical or saucer springs
- Belts: V-belts in “sandwich design”

#### Material

- Housing: aluminium diecast or cast iron according to size
- Variable speed pulleys: aluminium diecast
- Hubs: St52-3K, polyamide coated
- Belts: composite material, conductive to ISO 1813

#### Mechanical efficiency

$0.79 < \eta <= 0.85$  (at rated torque), depending on the output speed

### Data specific for belt variable speed drives

Compact unit Size	$P_{2perm}$ ( $n_{2min} \cdot n_{2max}$ ) [kW]	$n_{2min} \cdot n_{2max}$ ( $n_1 = 1400/min$ ) [1/min]	Setting range	V-belt W x H [mm x mm]	J [ $10^{-3} \text{ kgm}^2$ ]	m [kg]
10	0.2..0.35	600-3320	5.8	14 x 5	0.25	0.46
13	0.5..1.3	620-3285	5.5	22 x 6	2.0	1.4
16	1.1..2.6	580-3540	6.3	28 x 8	3.2	2.2
20	1.7..4.7	565-3675	6.7	37 x 10	7.1	3.4
25	3.5..9.4	570-3725	6.7	47 x 13	20	6.6

### Determination of the rated point ( $P_1$ , $M_2$ , $n_2$ )

The rated point results from the maximum drive power required by the whole speed-torque profile. The rated point is at  $n_{2max}$  when the torque requirement

- is constant
- corresponds to the torque characteristic of the compact unit (see fig.).

### Rated point $n_{2max}$ (50 Hz)

Features:

- Large speed setting range  $< = 6...7$
- For short time up to double (maximum) torque at  $n_{2min}$  (Caution: Corresponds to many times the rated torque!)
- Good self ventilation of the motor because of constant motor speed at mains frequency.

Technical notes:

- Variable speed drives are designed for operation with low switching frequency. For high switching frequencies please contact the manufacturer.
- The torque values  $M_2$  (at  $n_{2min}$ ) indicated in the selection tables can be considerably exceeded under operation with wrong selection.

### Torque characteristic

(under ideal operating conditions)

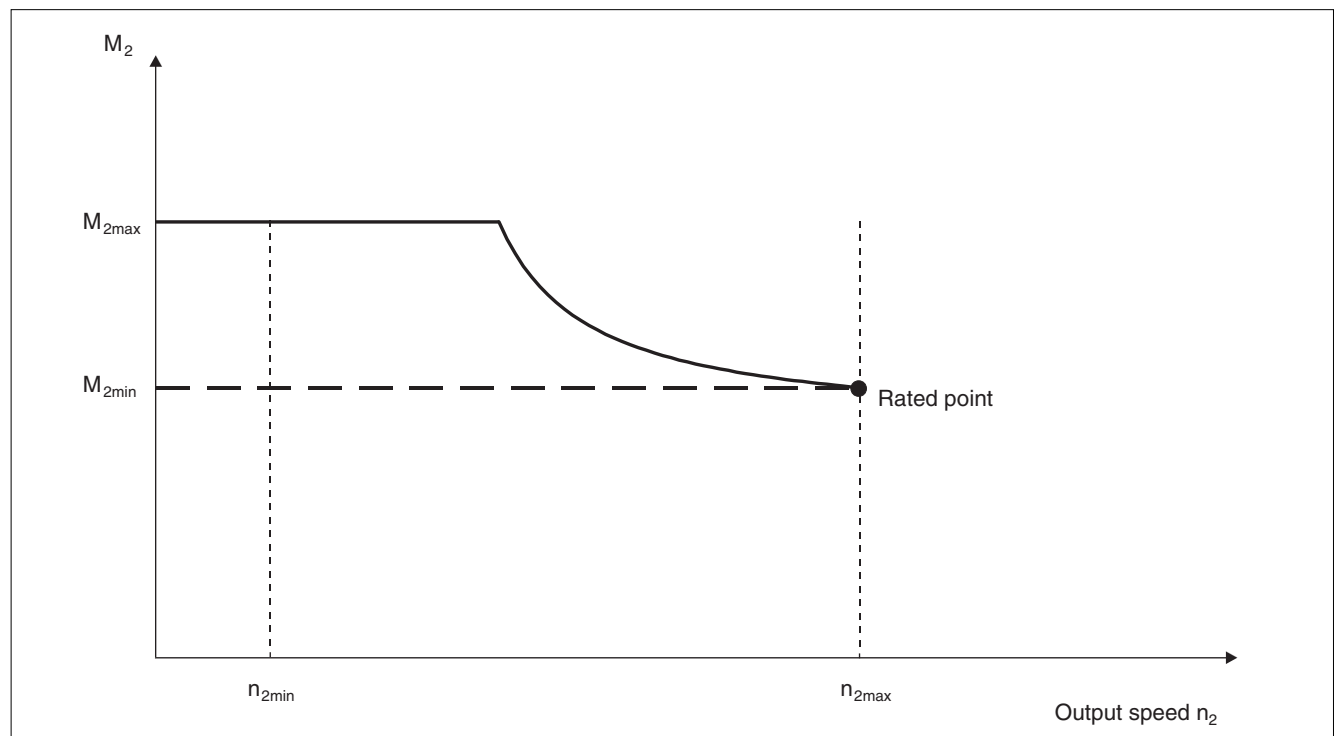

# Compact units

## Selection of dimensions

### Determination of the operating factor k

#### Requirements:

- $M_2 \geq M_N \cdot k$   
( $M_2$  from selection tables)

#### 1. Determining load class from type of input load:

Load class	Type of load and intensity
I	regular operation, virtually shock-free
II	irregular operation, moderate shocks
III	irregular operation, strong shocks and/or changing load

#### 2. Determination of the ambient temperature

#### 3. Read operating factor k from chart

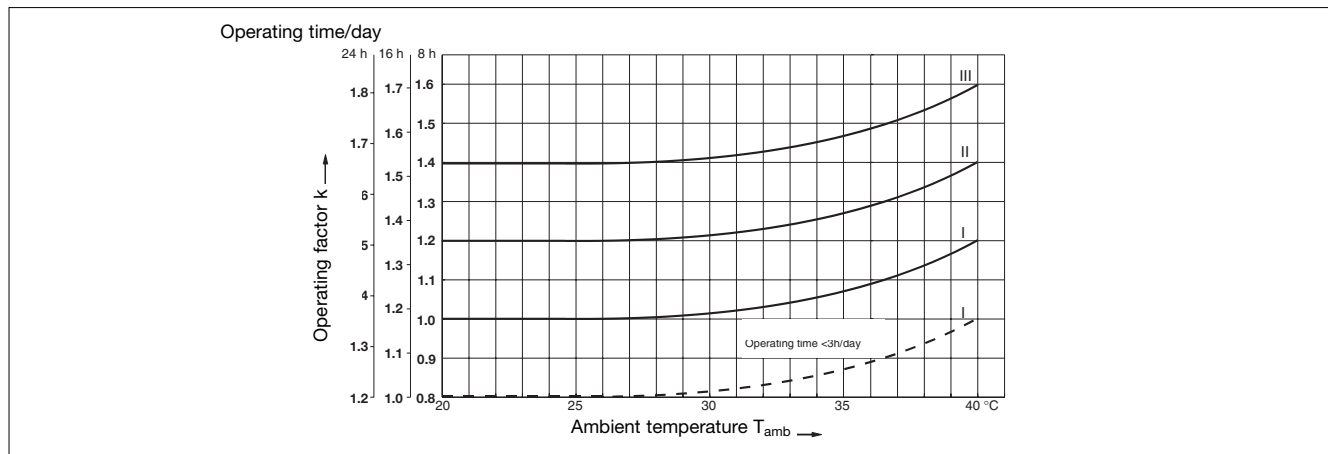

### Determination of the effective forces

#### Requirements:

- $F_{rperm} \geq F_r$   
( $F_{rperm}$  from General data gearbox)

#### 1. Determining the radial force:

- The acting radial forces depend on the application.
- For transmission elements  $F_r = \frac{2000 \cdot M_2 \cdot f_z}{d_w}$   
from table:

$f_z$	Transmission element
1.12	toothed gears
1.25 ... 1.4	chain wheels
1.5	crown gears
1.5 ... 2.0	small V-belt pulleys depending on initial tension

#### 2. Determining the axial force

- The effective axial forces depend on the application.

Selection table

P <sub>1</sub>	n <sub>2</sub> [1/min]	M <sub>2</sub> [Nm]	Type	IEC-motor	i	Figure No.	Page	
			□ = 3 = U-Configuration □ = 4 = Z-Configuration					
<b>0.25 kW</b>	621 – 124	2.7 – 14	11.4.□ 5.10.04.1	71–4	5	120/134	64/66	
	414 – 83	3.9 – 20	11.4.□ 5.10.04.1	71–4	7	120/134	64/66	
	300 – 60	5.4 – 26	11.4.□ 5.10.04.1	71–4	10	120/134	64/66	
	231 – 46	6.5 – 24	11.4.□ 5.10.04.1	71–4	13	120/134	64/66	
	207 – 41	7.2 – 34	11.4.□ 5.10.04.1	71–4	15	120/134	64/66	
	150 – 30	9.7 – 40	11.4.□ 5.10.04.1	71–4	20	120/134	64/66	
	115 – 23	13 – 28	11.4.□ 5.10.04.1	71–4	26	120/134	64/66	
	103 – 21	13 – 53	11.4.□ 5.10.04.1	71–4	30	120/134	64/66	
	75 – 15	16 – 37	11.4.□ 5.10.04.1	71–4	40	120/134	64/66	
	58 – 12	17 – 24	11.4.□ 5.10.04.1	71–4	53	120/134	64/66	
	48 – 9.7	18 – 23	11.4.□ 5.10.04.1	71–4	60	120/134	64/66	
	<b>0.37 kW</b>	621 – 124	4.0 – 14	11.4.□ 5.10.04.1	71–4	5	120/134	64/66
		414 – 83	5.8 – 20	11.4.□ 5.10.04.1	71–4	7	120/134	64/66
		300 – 60	7.9 – 26	11.4.□ 5.10.04.1	71–4	10	120/134	64/66
231 – 46		9.7 – 24	11.4.□ 5.10.04.1	71–4	13	120/134	64/66	
207 – 41		11 – 34	11.4.□ 5.10.04.1	71–4	15	120/134	64/66	
150 – 30		14 – 40	11.4.□ 5.10.04.1	71–4	20	120/134	64/66	
115 – 23		17 – 28	11.4.□ 5.10.04.1	71–4	26	120/134	64/66	
103 – 21		18 – 53	11.4.□ 5.10.04.1	71–4	30	120/134	64/66	
75 – 15		23 – 37	11.4.□ 5.10.04.1	71–4	40	120/134	64/66	
58 – 12		24 – 24	11.4.□ 5.10.04.1	71–4	53	120/134	64/66	
48 – 9.7		23 – 23	11.4.□ 5.10.04.1	71–4	60	120/134	64/66	
<b>0.55 kW</b>		621 – 128	6.0 – 30	11.4.□ 5.13.05.2	80–4	5	121/135	64/66
		414 – 86	8.7 – 43	11.4.□ 5.13.05.2	80–4	7	121/135	64/66
		316 – 65	11 – 55	11.4.□ 5.13.05.2	80–4	10	121/135	64/66
	226 – 47	15 – 41	11.4.□ 5.13.05.2	80–4	13	121/135	64/66	
	207 – 43	16 – 76	11.4.□ 5.13.05.2	80–4	15	121/135	64/66	
	158 – 33	20 – 95	11.4.□ 5.13.05.2	80–4	20	121/135	64/66	
	113 – 23	26 – 53	11.4.□ 5.13.05.2	80–4	26	121/135	64/66	
	103 – 21	27 – 107	11.4.□ 5.13.05.2	80–4	30	121/135	64/66	
	79 – 16	34 – 99	11.4.□ 5.13.05.2	80–4	40	121/135	64/66	
	57 – 12	41 – 54	11.4.□ 5.13.05.2	80–4	53	121/135	64/66	
	48 – 10	43 – 62	11.4.□ 5.13.05.2	80–4	60	121/135	64/66	
	<b>0.75 kW</b>	621 – 128	8.1 – 33	11.4.□ 5.13.05.2	80–4	5	121/135	64/66
		414 – 86	12 – 48	11.4.□ 5.13.05.2	80–4	7	121/135	64/66
		316 – 65	15 – 62	11.4.□ 5.13.05.2	80–4	10	121/135	64/66
226 – 47		20 – 41	11.4.□ 5.13.05.2	80–4	13	121/135	64/66	
207 – 43		22 – 85	11.4.□ 5.13.05.2	80–4	15	121/135	64/66	
158 – 33		28 – 106	11.4.□ 5.13.05.2	80–4	20	121/135	64/66	
113 – 23		36 – 53	11.4.□ 5.13.05.2	80–4	26	121/135	64/66	
103 – 21		37 – 107	11.4.□ 5.13.05.2	80–4	30	121/135	64/66	
79 – 16		46 – 99	11.4.□ 5.13.05.2	80–4	40	121/135	64/66	
57 – 12		50 – 54	11.4.□ 5.13.05.2	80–4	53	121/135	64/66	
48 – 10		59 – 62	11.4.□ 5.13.05.2	80–4	60	121/135	64/66	
37 – 7.6		65 – 88	11.4.□ 5.13.06.2	80–4	80	123/137	64/66	
<b>1.1 kW</b>		621 – 128	12 – 33	11.4.□ 5.13.05.3	90–4	5	122/136	64/66
		414 – 86	18 – 48	11.4.□ 5.13.05.3	90–4	7	122/136	64/66
	316 – 65	23 – 62	11.4.□ 5.13.05.3	90–4	10	122/136	64/66	
	226 – 47	30 – 41	11.4.□ 5.13.05.3	90–4	13	122/136	64/66	
	207 – 43	32 – 85	11.4.□ 5.13.05.3	90–4	15	122/136	64/66	
	158 – 33	41 – 105	11.4.□ 5.13.05.3	90–4	20	122/136	64/66	
	113 – 23	52 – 52	11.4.□ 5.13.05.3	90–4	26	122/136	64/66	
	103 – 21	54 – 107	11.4.□ 5.13.05.3	90–4	30	122/136	64/66	
	67 – 99	46 – 99	11.4.□ 5.13.05.3	90–4	40	122/136	64/66	
	59 – 12	87 – 176	11.4.□ 5.13.06.3	90–4	53	124/138	64/66	
	49 – 10	88 – 147	11.4.□ 5.13.06.3	90–4	60	124/138	64/66	

# Compact units

## Drive selection

Selection table

P <sub>1</sub>	n <sub>2</sub> [1/min]	M <sub>2</sub> [Nm]	Type	IEC-motor	i	Figure No.	Page	
			□ = 3 = U-Configuration □ = 4 = Z-Configuration					
<b>1.5 kW</b>	621–128	16–33	11.4.□5.13.05.3	90–4	5	122/136	64/66	
	414–86	24–48	11.4.□5.13.05.3	90–4	7	122/136	64/66	
	316–65	31–62	11.4.□5.13.05.3	90–4	10	122/136	64/66	
	226–47	41–41	11.4.□5.13.05.3	90–4	13	122/136	64/66	
	207–43	44–85	11.4.□5.13.05.3	90–4	15	122/136	64/66	
	158–33	56–106	11.4.□5.13.05.3	90–4	20	122/136	64/66	
	118–24	73–142	11.4.□5.13.05.3	90–4	26	122/136	64/66	
	103–21	70–107	11.4.□5.13.05.3	90–4	30	122/136	64/66	
	59–12	119–176	11.4.□5.13.06.3	90–4	53	124/138	64/66	
	49–10	115–147	11.4.□5.13.06.3	90–4	60	124/138	64/66	
37–7.1	156–195	11.4.□5.16.08.2	90–4	80	127/141	64/66		
<b>2.2 kW</b>	621–120	26–79	11.4.□5.16.06.3	100–4	5	126/140	64/66	
	414–80	38–114	11.4.□5.16.06.3	100–4	7	126/140	64/66	
	308–60	50–151	11.4.□5.16.06.3	100–4	10	126/140	64/66	
	235–46	65–158	11.4.□5.16.06.3	100–4	13	126/140	64/66	
	207–40	70–188	11.4.□5.16.06.3	100–4	15	126/140	64/66	
	154–30	92–226	11.4.□5.16.06.3	100–4	20	126/140	64/66	
	118–23	116–188	11.4.□5.16.06.3	100–4	26	126/140	64/66	
	103–20	109–184	11.4.□5.16.06.3	100–4	30	126/140	64/66	
	75–15	156–381	11.4.□5.16.08.3	100–4	40	128/142	64/66	
	57–11	197–404	11.4.□5.16.08.3	100–4	53	128/142	64/66	
	49–9.4	179–314	11.4.□5.16.08.3	100–4	60	128/142	64/66	
	<b>3.0 kW</b>	621–120	35–79	11.4.□5.16.06.3	100–4	5	126/140	64/66
		414–80	52–114	11.4.□5.16.06.3	100–4	7	126/140	64/66
308–60		69–151	11.4.□5.16.06.3	100–4	10	126/140	64/66	
235–46		88–158	11.4.□5.16.06.3	100–4	13	126/140	64/66	
207–40		95–188	11.4.□5.16.06.3	100–4	15	126/140	64/66	
154–30		125–226	11.4.□5.16.06.3	100–4	20	126/140	64/66	
118–23		152–188	11.4.□5.16.06.3	100–4	26	126/140	64/66	
100–20		168–336	11.4.□5.16.08.3	100–4	30	128/142	64/66	
75–15		207–381	11.4.□5.16.08.3	100–4	40	128/142	64/66	
<b>4.0 kW</b>		600–113	49–131	11.4.□5.20.10.3	112–4	5	130/144	64/66
		400–75	72–191	11.4.□5.20.10.3	112–4	7	130/144	64/66
	300–57	94–251	11.4.□5.20.10.3	112–4	10	130/144	64/66	
	231–44	121–319	11.4.□5.20.10.3	112–4	13	130/144	64/66	
	200–38	132–348	11.4.□5.20.10.3	112–4	15	130/144	64/66	
	150–28	172–453	11.4.□5.20.10.3	112–4	20	130/144	64/66	
	115–22	217–568	11.4.□5.20.10.3	112–4	26	130/144	64/66	
	100–19	224–564	11.4.□5.20.10.3	112–4	30	130/144	64/66	
	75–14	288–660	11.4.□5.20.10.3	112–4	40	130/144	64/66	
	58–11	352–713	11.4.□5.20.10.3	112–4	53	130/144	64/66	
	<b>5.5 kW</b>	600–113	67–131	11.4.□5.20.10.3	112–4	5	130/144	64/66
400–75		98–191	11.4.□5.20.10.3	112–4	7	130/144	64/66	
300–57		130–251	11.4.□5.20.10.3	112–4	10	130/144	64/66	
231–44		166–319	11.4.□5.20.10.3	112–4	13	130/144	64/66	
200–38		181–348	11.4.□5.20.10.3	112–4	15	130/144	64/66	
150–28		237–453	11.4.□5.20.10.3	112–4	20	130/144	64/66	
115–22		299–568	11.4.□5.20.10.3	112–4	26	130/144	64/66	
100–19		278–564	11.4.□5.20.10.3	112–4	30	130/144	64/66	
58–11		486–952	11.4.□5.20.12.3	112–4	53	131/145	64/66	

Selection table

$P_1$	$n_2$ [1/min]	$M_2$ [Nm]	Type	IEC-motor	$i$	Figure No.	Page	
<b>7.5 kW</b>	621-118	89-262	11.435.25.12.2	132-4	5	132	64	
	414-79	130-382	11.435.25.12.2	132-4	7	132	64	
	300-57	177-519	11.435.25.12.2	132-4	10	132	64	
	231-44	227-663	11.435.25.12.2	132-4	13	132	64	
	207-40	239-702	11.435.25.12.2	132-4	15	132	64	
	150-29	322-943	11.435.25.12.2	132-4	20	132	64	
	115-22	409-1194	11.435.25.12.2	132-4	26	132	64	
	103-20	396-919	11.435.25.12.2	132-4	30	132	64	
	<b>9.2 kW</b>	621-118	109-262	11.435.25.12.2	132-4	5	132	64
414-79		159-382	11.435.25.12.2	132-4	7	132	64	
300-57		217-519	11.435.25.12.2	132-4	10	132	64	
231-44		278-663	11.435.25.12.2	132-4	13	132	64	
207-40		293-702	11.435.25.12.2	132-4	15	132	64	
150-29		395-943	11.435.25.12.2	132-4	20	132	64	
115-22		502-1194	11.435.25.12.2	132-4	26	132	64	
<b>11 kW</b>		621-118	130-262	11.435.25.12.3	160-4	5	133	64
		414-79	190-382	11.435.25.12.3	160-4	7	133	64
	300-57	259-519	11.435.25.12.3	160-4	10	133	64	
	231-44	333-663	11.435.25.12.3	160-4	13	133	64	
	207-40	351-702	11.435.25.12.3	160-4	15	133	64	
	150-29	473-943	11.435.25.12.3	160-4	20	133	64	
	115-22	588-1194	11.435.25.12.3	160-4	26	133	64	

# Compact units

## Drive selection

### Dimensions U-configuration

#### Foot-mounted design

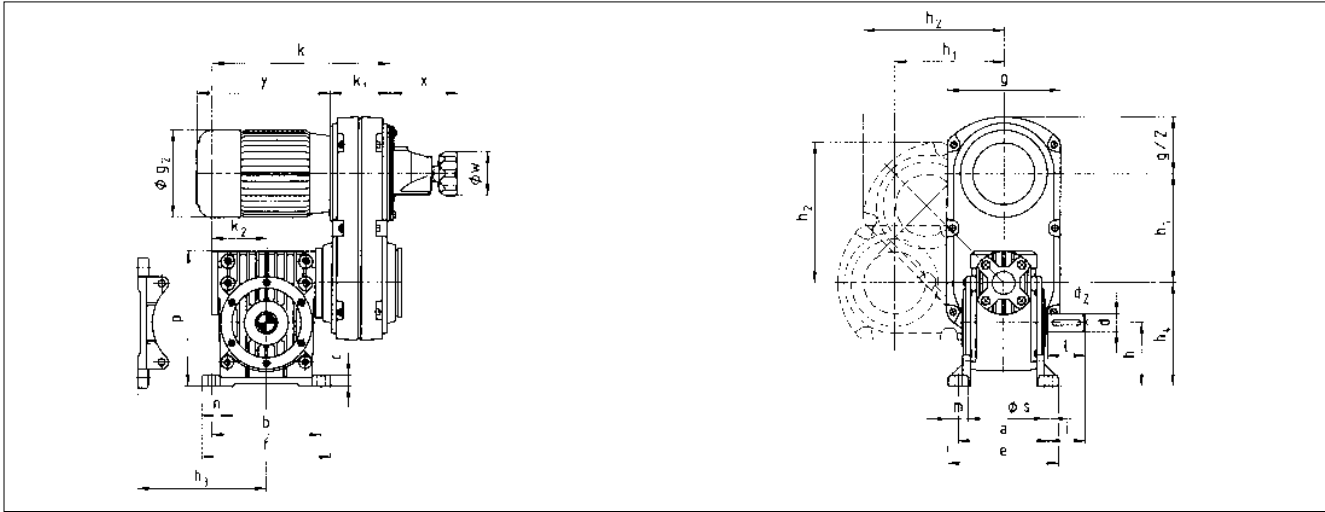

#### Flange-mounted design

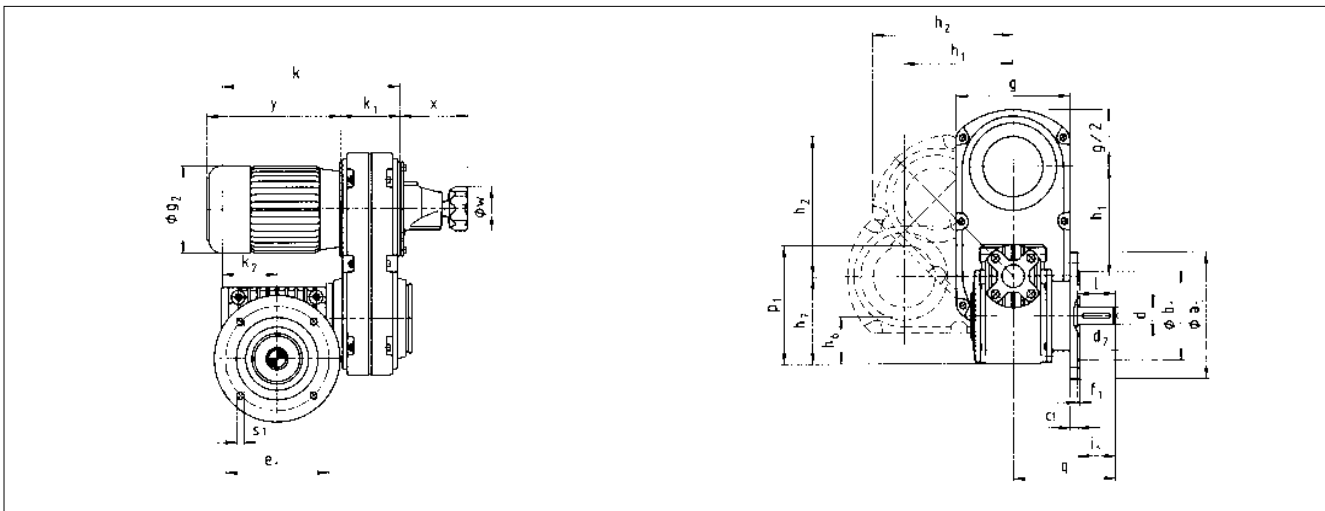

#### Hollow shaft design

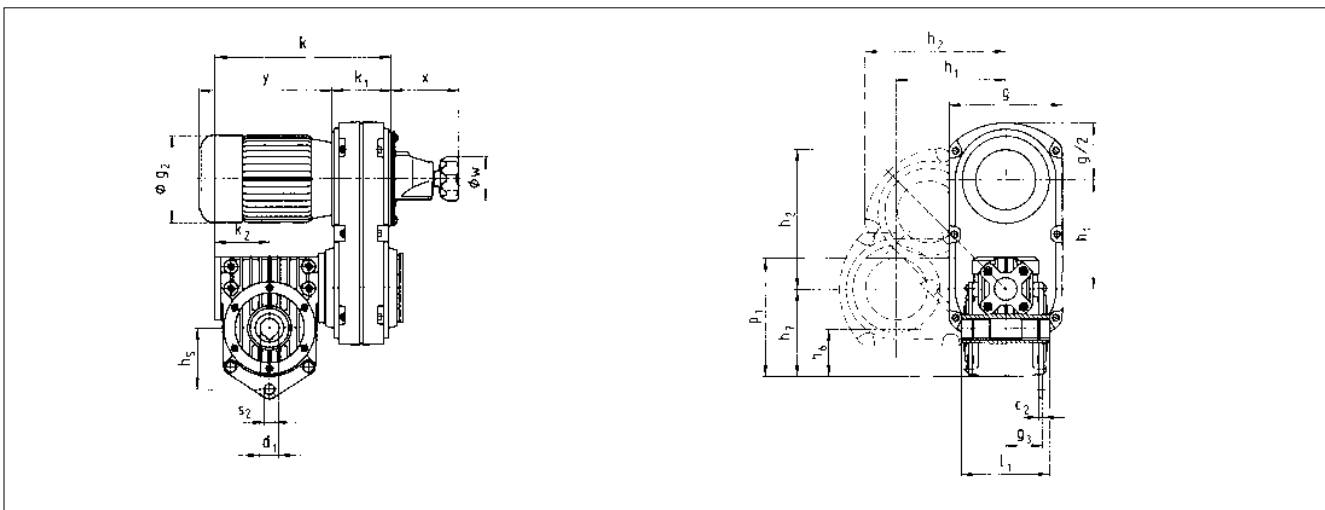



### Dimensions U-configuration

#### Flange hollow shaft design

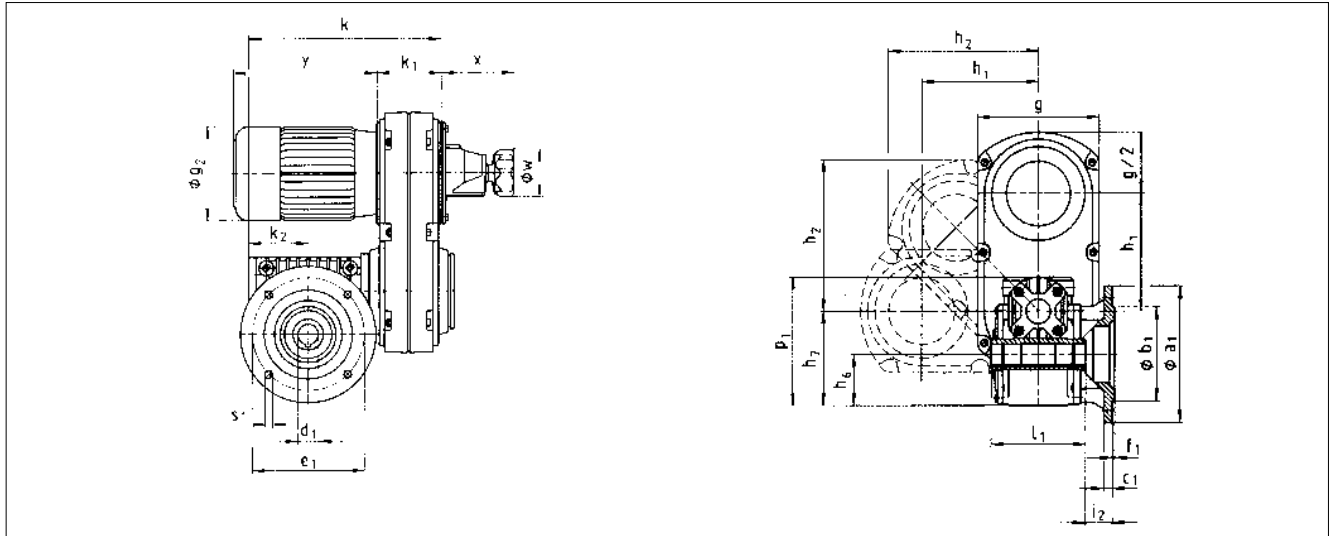

### Dimensions

Fig. No.	Type	Motor	Belt	Basic dimensions																			m <sup>1)</sup> [kg]			
				g	g <sub>2</sub> <sup>1)</sup>	g <sub>3</sub>	h	h <sub>1</sub>	h <sub>2</sub>	h <sub>3</sub>	h <sub>4</sub>	h <sub>5</sub>	h <sub>6</sub>	h <sub>7</sub>	k	k <sub>1</sub>	k <sub>2</sub>	m	n	p	p <sub>1</sub>	q		w	x	y <sup>1)</sup>
120	11.435.10.04.1	71	13/475	135	142	43	67	136	172	71	107	69	51	91	208	65	65	21	35	145	128	122	70	100	212	18
121	11.435.13.05.2	80	22/610	180	156	50	83	173	223	83	133	82	62	112	254	95	73	27	44	174	153	149	70	108	234	30
122	11.435.13.05.3	90			276																				41	
123	11.435.13.06.2	80			156																				234	37
124	11.435.13.06.3	90			178																				276	48
125	11.435.16.06.2	90	28/750	212	178	59	100	217	272	100	163	97	75	138	299	110	88	32	48	215	190	172	105	147	276	52
126	11.435.16.06.3	100			198																				308	60
127	11.435.16.08.2	90			178																				276	66
128	11.435.16.08.3	100			198																				308	74
129	11.435.20.10.2	100	37/900	263	198	75	150	248	321	150	250	138	110	210	391	130	118	40	63	315	275	234	105	147	308	103
130	11.435.20.10.3	112			222																				333	114
131	11.435.20.12.3	112			222																				333	140
132	11.435.25.12.2	132			262																				405	183
133	11.435.25.12.3	160	47/1120	320	317	93	186	316	402	186	311	167	141	266	476	160	146	48	67	385	340	272	160	184	501	223

Type	Foot									Flange								Shaft			Hollow shaft			
	a	b	c	e	f	i	m	n	s	a <sub>1</sub>	b <sub>1</sub> <sup>3)</sup>	c <sub>1</sub>	c <sub>2</sub>	e <sub>1</sub>	f <sub>1</sub>	i <sub>1</sub>	i <sub>2</sub>	s <sub>1</sub>	s <sub>2</sub>	d <sup>2)</sup>	l	d <sub>2</sub>	d <sub>1</sub> <sup>H7</sup>	l <sub>1</sub>
11.435.10.04.1	98	118	11	122	140	51	21	35	10	120 140	80 95	8	5	100 115	3	50	29	6.6 9	10.5	19	50	M 6	20	100
11.435.13.05.□	114	152	14	146	180	63	27	44	10	140 160	95 110	10	6	115 130	3 3.5	60	39	9	12.5	24	60	M 8	25	120
11.435.13.06.□	136	174	17	175	205	72	32	48	12	160 200	110 130	12	6	130 165	3.5	70	40	9 11	16.5	28	70	M10	30	140
11.435.16.06.□	136	174	17	175	205	72	32	48	12	160 200	110 130	12	6	130 165	3.5	70	40	9 11	16.5	28	70	M10	30	140
11.435.16.08.□	166	212	19	200	245	82	32	58	14	200 250	130 180	14	6	165 215	3.5 4	80	54	11 14	16.5	38	80	M12	40	170
11.435.20.10.□	194	240	22	234	280	93	40	63	18	250 300	180 230	16	6	215 265	4	100	59	14	20.5	48	100	M16	50	180
11.435.20.12.3	235	300	25	286	350	101	48	67	22	300 350	230 250	20	6	265 300	4 5	110	68	14 18	20.5	55	110	M20	70	215
11.435.25.12.□	235	300	25	286	350	101	48	67	22	300 350	230 250	20	6	265 300	4 5	110	68	14 18	20.5	55	110	M20	70	215

1) Deviations in motor dimensions possible.

2) ISO tolerance up to Ø 50 mm = k6; more than Ø 50 mm = m6

3) ISO tolerance up to Ø 230 mm = j7; more than Ø 230 mm = h7

Keys to DIN 6885/1

Dimensions in [mm]

# Compact units

## Drive selection

### Dimensions Z-configuration

#### Foot-mounted design

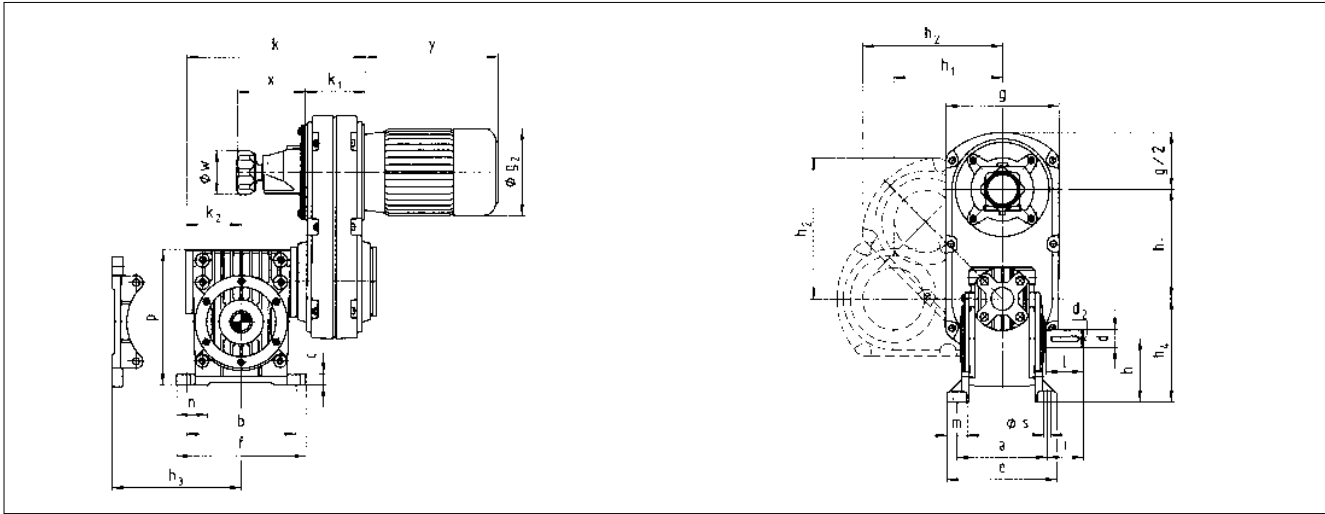

#### Flange-mounted design

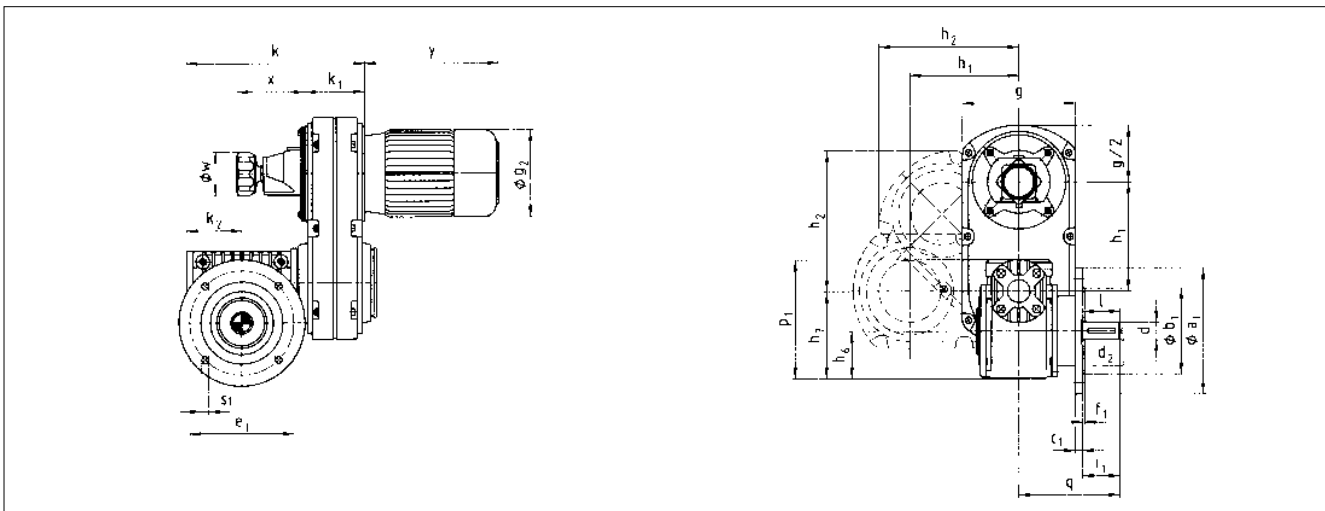

#### Hollow shaft design

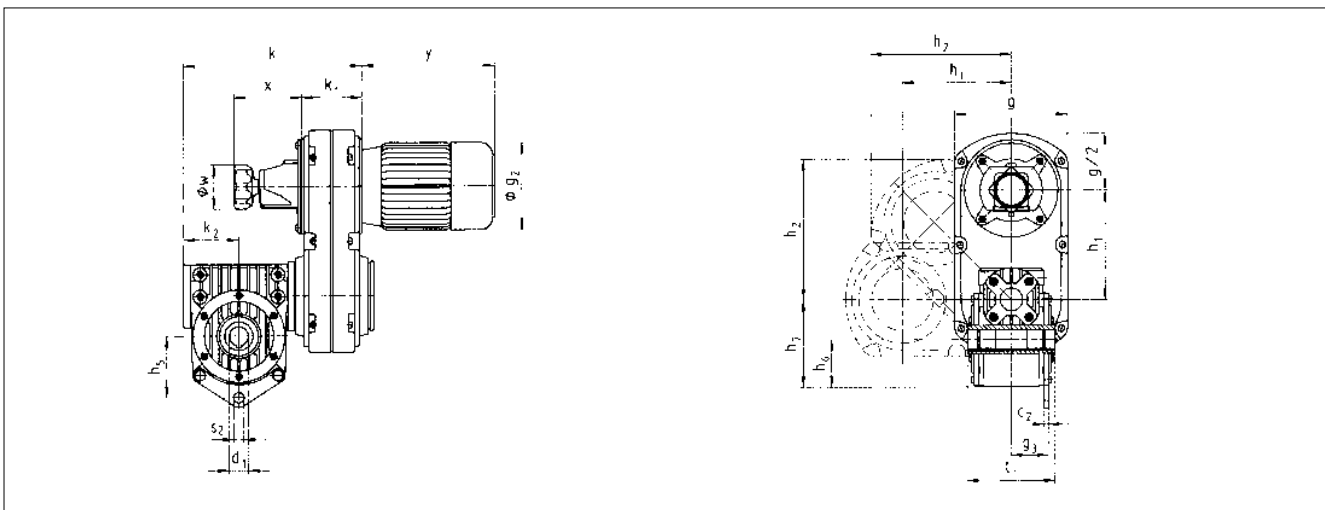

### Dimensions Z-configuration

#### Flange hollow shaft design

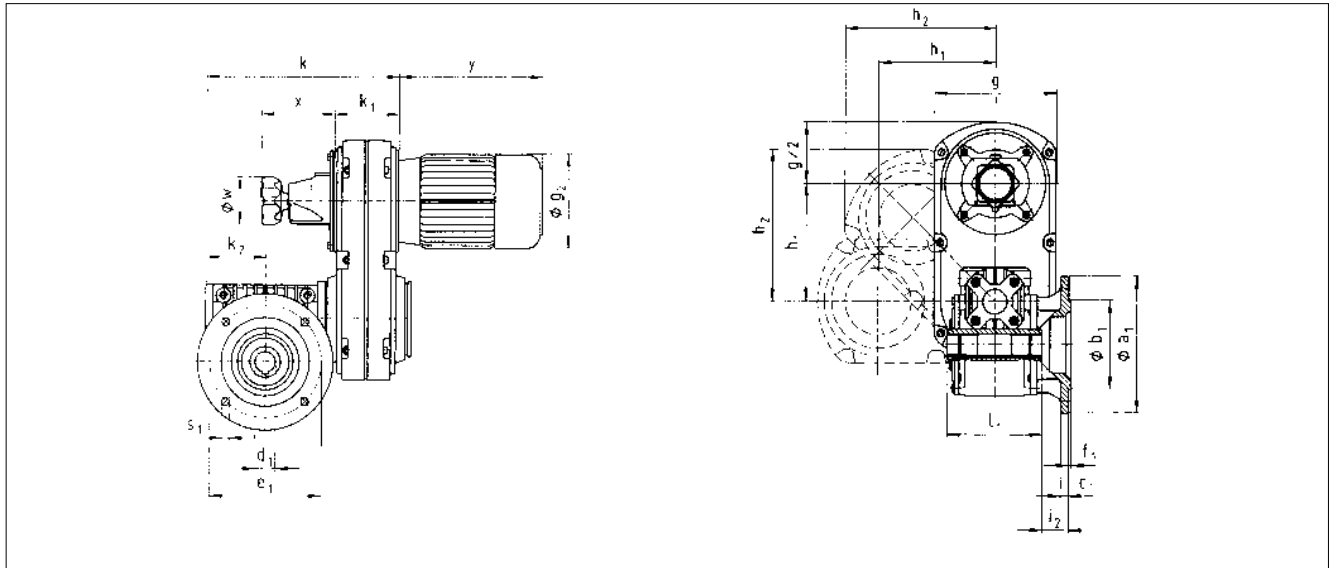

#### Dimensions

Fig. No.	Type	Motor	Belt	Basic dimensions																			m <sup>1)</sup> [kg]			
				g	g <sub>2</sub> <sup>1)</sup>	g <sub>3</sub>	h	h <sub>1</sub>	h <sub>2</sub>	h <sub>3</sub>	h <sub>4</sub>	h <sub>5</sub>	h <sub>6</sub>	h <sub>7</sub>	k	k <sub>1</sub>	k <sub>2</sub>	m	n	p	p <sub>1</sub>	q	w	x	y <sup>1)</sup>	
134	11.445.10.04.1	71	13/475	135	142	43	67	136	172	71	107	69	51	91	208	65	65	21	35	145	128	122	70	100	212	18
135	11.445.13.05.2	80	22/610	180	156	50	83	173	223	83	133	82	62	112	254	95	73	27	44	174	153	149	70	108	234	30
136	11.445.13.05.3	90			178																				276	41
137	11.445.13.06.2	80			156																				234	37
138	11.445.13.06.3	90			178																				276	48
139	11.445.16.06.2	90	28/750	212	178	59	100	217	272	100	163	97	75	138	299	110	88	32	48	215	190	172	105	147	276	52
140	11.445.16.06.3	100			198																				308	60
141	11.445.16.08.2	90			178																				276	66
142	11.445.16.08.3	100			198																				308	74
143	11.445.20.10.2	100	37/900	263	198	75	150	248	321	150	250	138	110	210	391	130	118	40	63	315	275	234	105	147	308	103
144	11.445.20.10.3	112			222																				333	114
145	11.445.20.12.3	112			222																				333	140

Type	Foot										Flange										Shaft			Hollow shaft	
	a	b	c	e	f	i	m	n	s	a <sub>1</sub>	b <sub>1</sub> <sup>3)</sup>	c <sub>1</sub>	c <sub>2</sub>	e <sub>1</sub>	f <sub>1</sub>	i <sub>1</sub>	i <sub>2</sub>	s <sub>1</sub>	s <sub>2</sub>	d <sup>2)</sup>	l	d <sub>2</sub>	d <sub>1</sub> <sup>H7</sup>	l <sub>1</sub>	
11.445.10.04.1	98	118	11	122	140	51	21	35	10	120 140	80 95	8	5	100 115	3	50	29	6.6 9	10.5	19	50	M 6	20	100	
11.445.13.05.□	114	152	14	146	180	63	27	44	10	140 160	95 110	10	6	115 130	3 3.5	60	39	9	12.5	24	60	M 8	25	120	
11.445.13.06.□	136	174	17	175	205	72	32	48	12	160 200	110 130	12	6	130 165	3.5	70	40	9 11	16.5	28	70	M10	30	140	
11.445.16.06.□	136	174	17	175	205	72	32	48	12	160 200	110 130	12	6	130 165	3.5	70	40	9 11	16.5	28	70	M10	30	140	
11.445.16.08.□	166	212	19	200	245	82	32	58	14	200 250	130 180	14	6	165 215	3.5 4	80	54	11 14	16.5	38	80	M12	40	170	
11.445.20.10.□	194	240	22	234	280	93	40	63	18	250 300	180 230	16	6	215 265	4	100	59	14	20.5	48	100	M16	50	180	
11.445.20.12.3	235	300	25	286	350	101	48	67	22	300 350	230 250	20	6	265 300	4 5	110	68	14 18	20.5	55	110	M20	70	215	

1) Deviations in motor dimensions possible.

2) ISO tolerance up to Ø 50 mm = k6; more than Ø 50 mm = m6

3) ISO tolerance up to Ø 230 mm = j7; more than Ø 230 mm = h7

Keys to DIN 6885/1  
Dimensions in [mm]

# Compact units

## Drive selection

### Options – Speed-adjustment unit

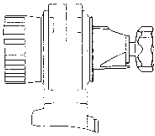
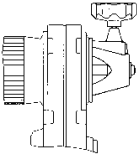
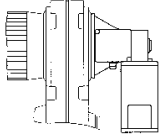
Name	Front adjustment (Standard)	Angle adjustment (Option)	Electric remote adjustment (Option)
Schematic sketch			
Installation	Hand wheel – impact resistant plastic – drive size 25: Aluminium	Hand wheel – impact resistant plastic	Servo motor – three-phase AC asynchronous motor – for techn. data see below
Location	– parallel axial to axis of variable speed pulley	– rectangular to axis of variable speed pulley	– rectangular to axis of variable speed pulley
Position indication	– in the housing of the adjustment unit	– in the housing of the adjustment unit	–
Position indication in hand wheel	Option – for scaling see below	Option – for scaling see below	–

### Controls: Type code

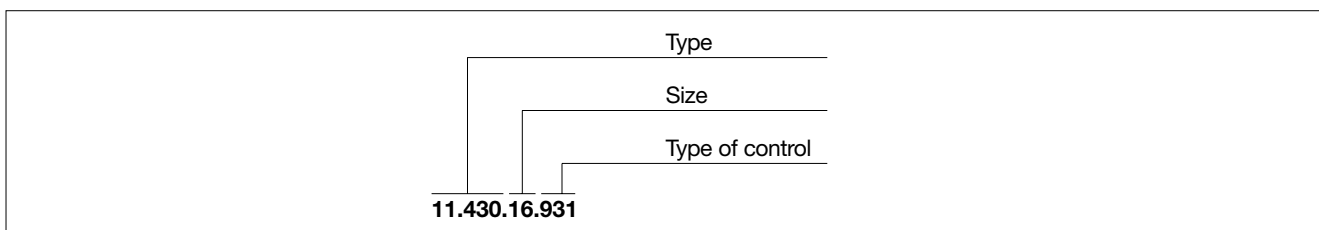

**Size:** 10, 13, 16, 25, 40

#### Type of control:

931 – Front control

932 – Angular control

933 – Electrical remote control, enclosure IP54

**Techn. data: servo motor** (for electric remote adjustm.)

Drive size	P1 [kW]	n1 [1/min]	Voltage/ frequency	Enclosure	Thermal class	Ratio small gearbox	Adjust. time [s]
10 13	0.012	1350	Δ 220-240V / 50 Hz Y 380-415V / 50 Hz	IP 54	F	60	approx. 15 approx. 22
16 20	0.060	1350	Δ 220-240V / 50 Hz Y 380-415V / 50 Hz	IP 54	F	55	approx. 26 approx. 35
25	0.060	1350	Δ 220-240V / 50 Hz Y 380-415V / 50 Hz	IP 54	F	50	approx. 40 approx. 50

### Options – Speed-adjustment units

#### Angular control

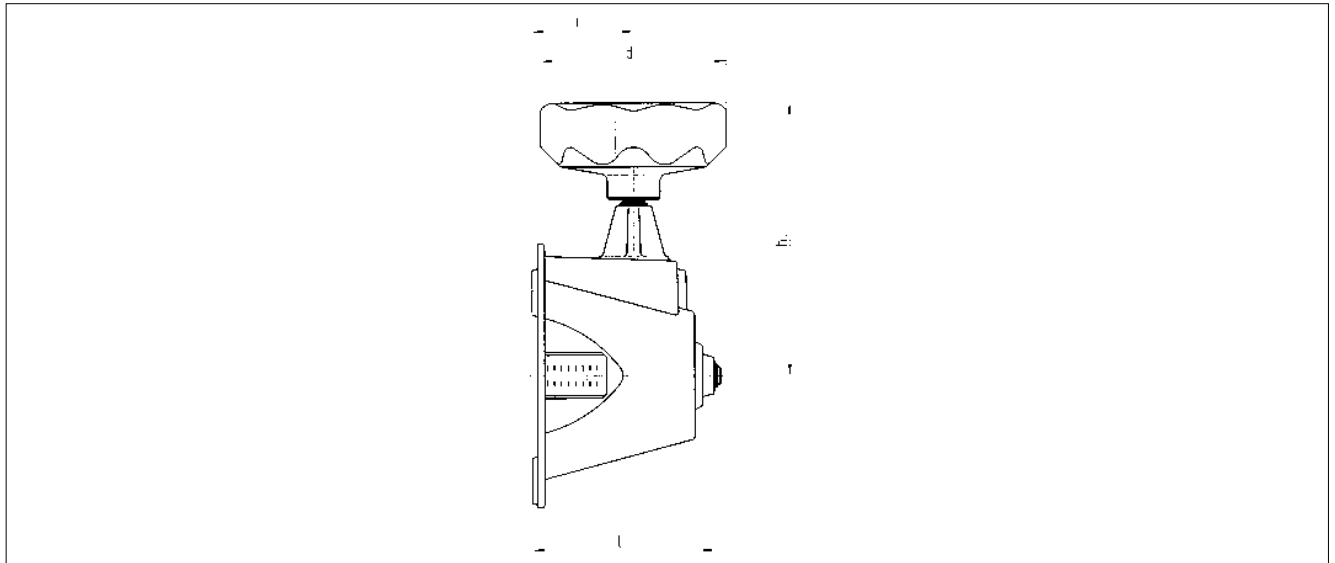

Compact Unit/ Size	Type	Angular control				Weight m [kg]
		d <sub>2</sub>	h <sub>2</sub>	l <sub>1</sub>	l <sub>2</sub>	
10	11.430.10.932	70	87	88	105	0.5
13	11.430.13.932	70	104	56	87	0.5
16 16	11.430.16.932 11.430.16.932	105	155	58	103	1.5
25	11.430.25.932	105	179	88	138	4

#### Electrical remote control

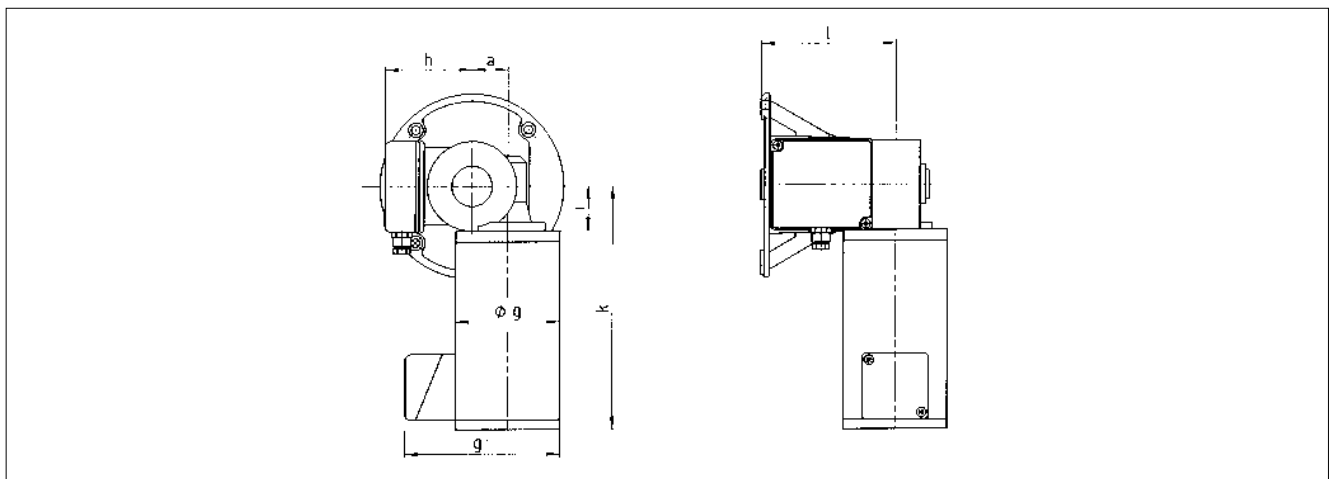

Compact Unit/ Size	Type	Electrical remote control							Weight m [kg]
		a	g	g <sub>1</sub>	h	i	k	l	
10	11.430.10.933	25	65	123	54	31	165	81	2.5
13	11.430.13.933	25	65	123	60	31	165	82	3.0
16 20	11.430.16.933 11.430.20.933	31	85	144	71	37	199	111	5.5
25	11.430.25.933	35	85	144	95	41	203	148	8

Dimensions in [mm]

# Compact units

## Drive selection

### Options – Speed-measuring unit

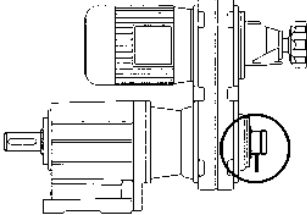
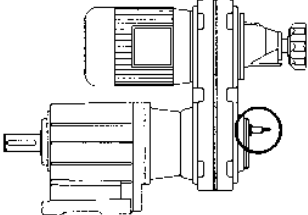
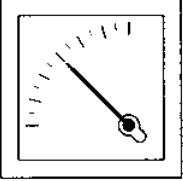
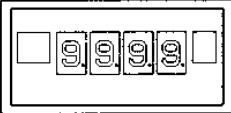
Name	DC speed encoder	Pulse encoder
Schematic sketch		
Installation	<ul style="list-style-type: none"> <li>- Speed encoder at output shaft of variable speed drives (Input shaft of reduction gearboxes)</li> <li>- Cable length: 1 m</li> </ul>	<ul style="list-style-type: none"> <li>- Speed encoder at output shaft of variable speed drives (Input shaft of reduction gearboxes)</li> <li>- Cable length: 2.5 m (max. cable length: 300 m)</li> </ul>
Regulations	see motors	DIN 19234 / NAMUR
Input voltage	- (Generator)	8.2 V ± 0.5 V (R <sub>i</sub> = 1kOhm ± 50 Ohm) Important: Lenze-Indicators export supply voltage!
Signal voltage	Analog n <sub>2 min</sub> : approx. 3 V n <sub>2 max</sub> : approx. 20 V (for R -> endless)	Digital 4 pulse/revolution > 1.2 V
Speed indicators - suitable for control-cabinet installation	Analog display - rear-side encoder input - scaling in (V), adjustable  	
Digital display		- rear-side generator output/input - 4-digit display - adjustable display  

**Options – Speed measuring units**

**DC speed encoder type 11.330.□□.931**

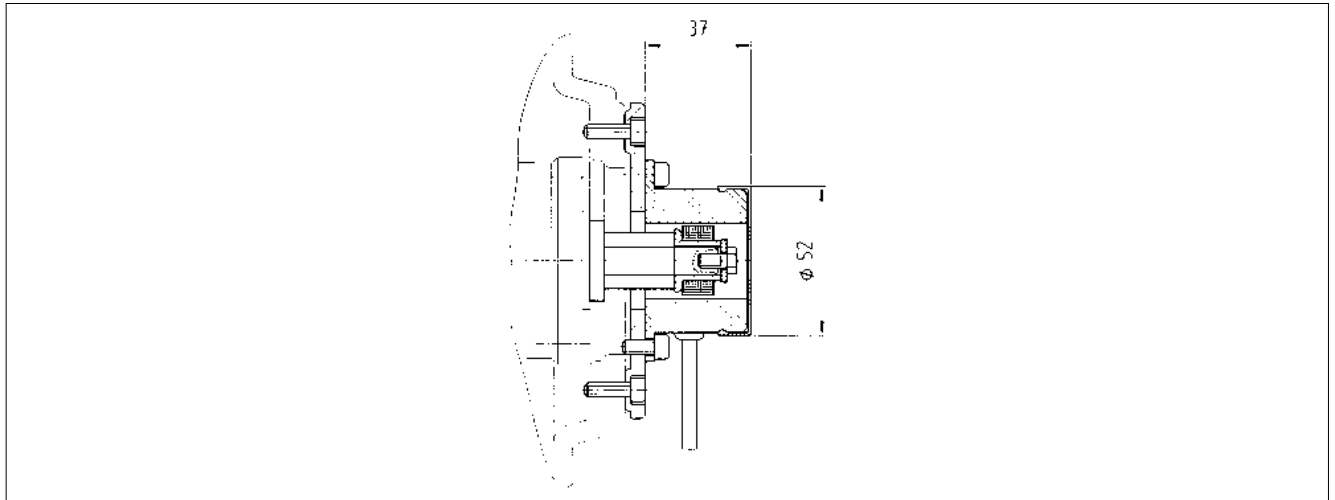

Dimensions in [mm]

**Pulse encoder type FGL 4/1.5 - 5K**

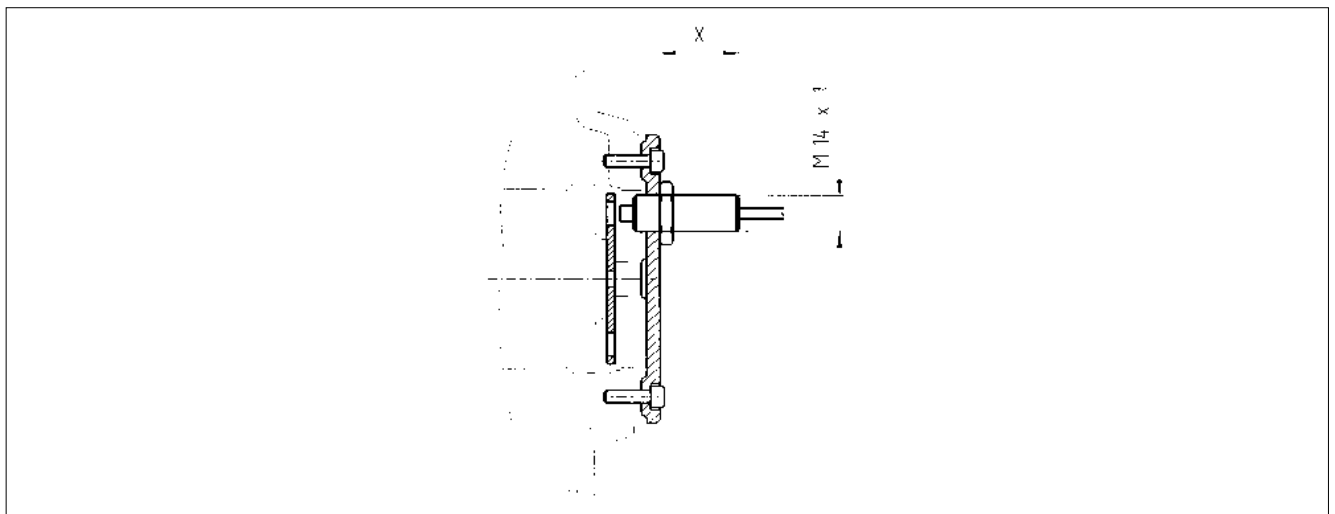

Compact unit/ Size	Pulse encoder x
10	approx. 34
13	approx. 32
16	approx. 33
20 25	approx. 19

Dimensions in [mm]

# Compact units

## Drive selection

### Options – Speed-measuring units

#### Hand wheel with position indicator

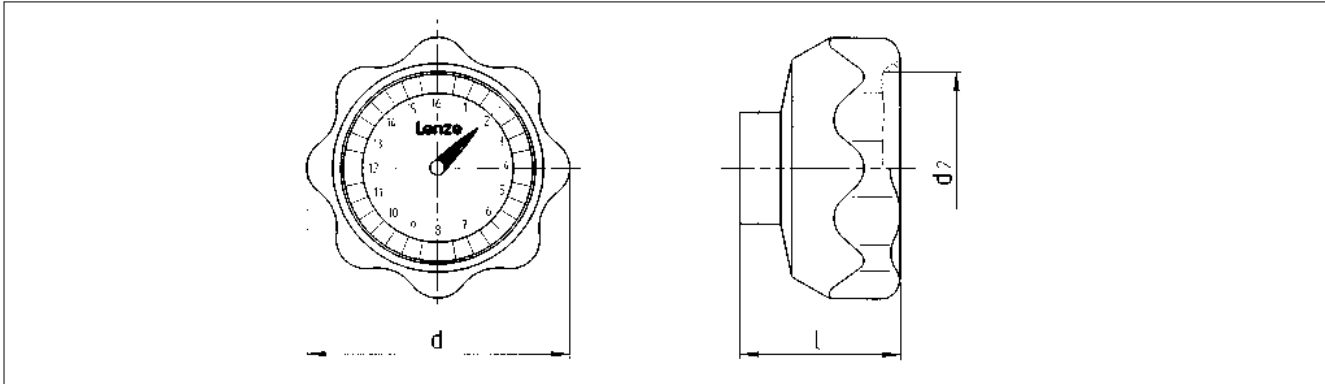

Hand wheel size		Hand wheel with position indicator		
Front adjustment	Angle adjustment	d	d <sub>2</sub>	l
HA 8	HA 8	70	52	43
HA 10	HA 10	105	87	55
HA 15		160	87	55

#### Position indicator in hand wheel: scaling

Compact unit size	10	13	16	20	25
Scaling	1..12	1..12	1..18	1..18	1..24

#### Analog display type DQW 96 RS

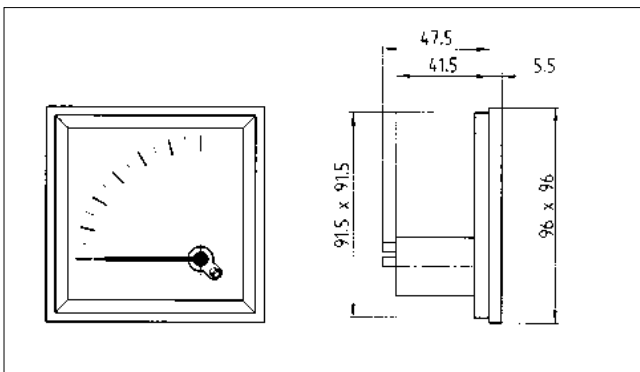

Dimensions in [mm]

#### Digital display type ELTA 2000 A

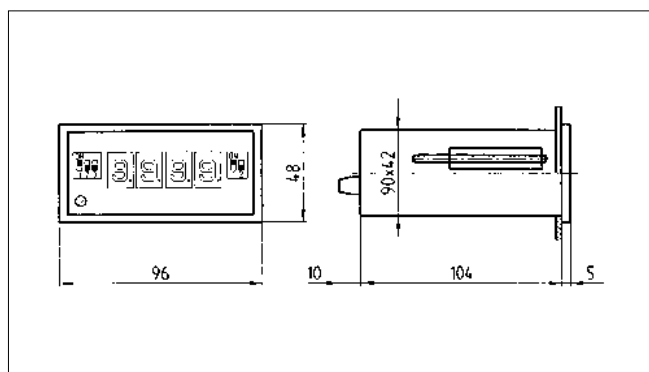



# DISCO-variable speed drive

## Product information

Illustrations _____	74
Type code _____	75
Order information _____	75

## Technical data

Mounting positions _____	76
Spindle housing position _____	76
Terminal box positions _____	76
General data _____	78

## Selection

<b>Selection</b>	
- Determination of the rated point _____	80
- Determination of the operating factor _____	81
- Determination of the effective forces _____	81

## Drive selection

<b>Selection tables</b> _____	82
<b>Dimensions</b> _____	84

### Options for DISCO-variable speed drives

#### Speed-adjustment units

- Spindle housing _____	92
- Bevel gear adjuster _____	92
- Electrical remote control _____	92

#### Speed-measuring units

- Inductive speed measurement _____	94
- Hand wheel indicator _____	94
- Analog display _____	94
- Digital display _____	94

### Options for gearboxes (see chapter geared motors) \_ 38

# ***DISCO-variable speed drive***

## ***Product information***

### **Illustrations**

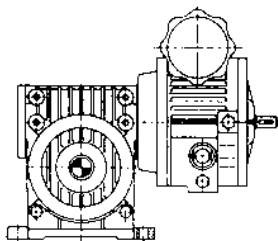

**11.705**

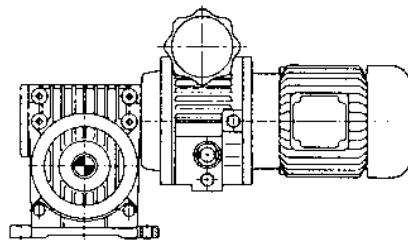

**11.715**

### Type code

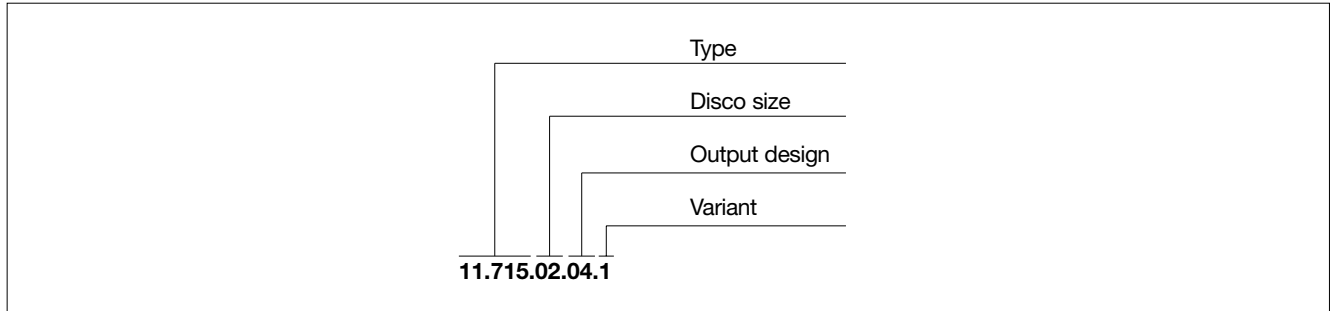

#### Type

11.715 Disco with motor  
11.705 Disco with free input shaft

#### Disco size

02 . . . 18

#### Output design

04 . . . 12 = size of the gearbox

#### Variant

no code = normal  
1 = without motor  
2 = without gearbox  
3 = without motor, without gearbox

#### Order information

- Complete type code
- Ratio
- Motor power and voltage
- Mounting positions and position of the terminal box
- Flange design: Output flange diameter
- Hollow shaft design: hollow shaft bore
- Speed-adjustment and position
- Disco options
- Gearbox options
- Motor options

### Necessary motor dimensions

Disco size	02	03	04	05	06	07	08/18
IEC-motor frame size	71	71	80	90	100	112	132
Motor design/Flange diameter	IM B14/C105	IM B14/C105	IM B5/A200	IM B51/A200	IM B5/A250	IM B5/A250	IM B5/A300
Motorshaft d x l (mm)	14 x 30	14 x 30	19 x 40	24 x 50	28 x 60	28 x 60	38 x 80

All motors must have oil seals in the flange.

# DISCO-variable speed drive

## Technical data

### Mountings

#### Foot-mounted design

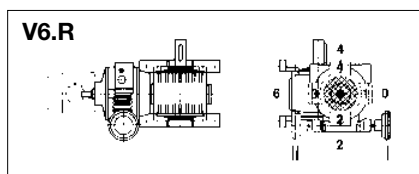
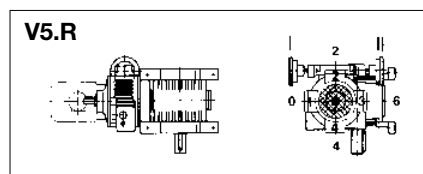
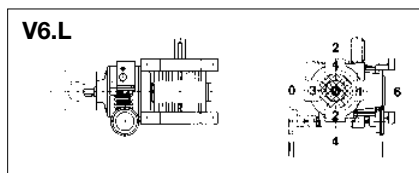
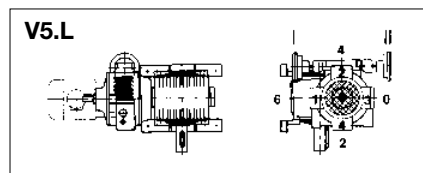
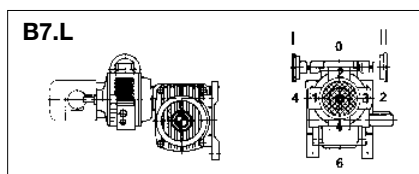
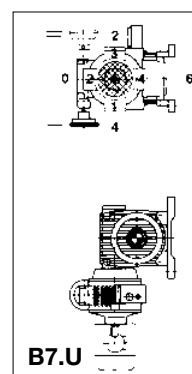
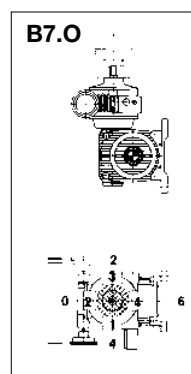
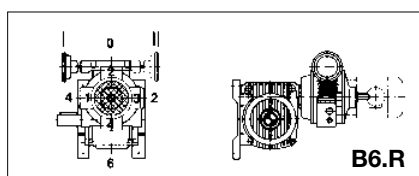
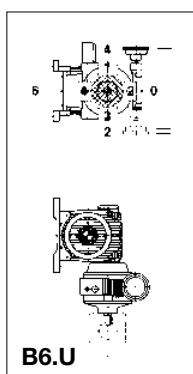
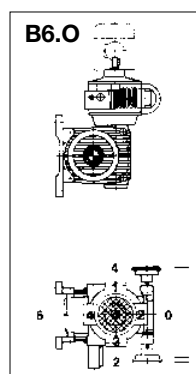
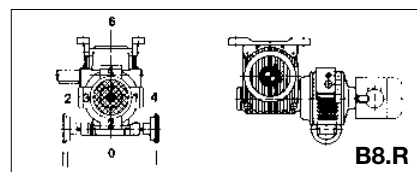
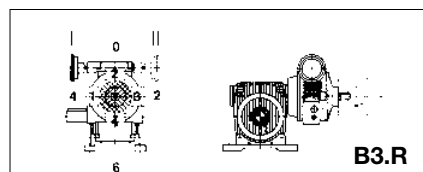
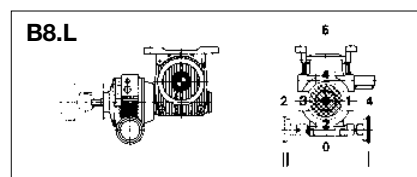
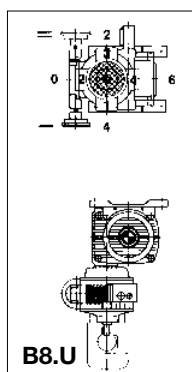
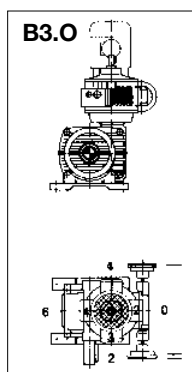
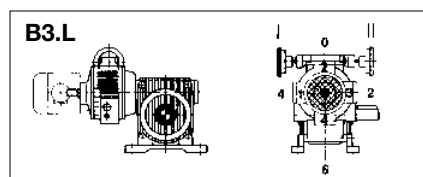

**Attention:** By changing the position of the adjuster to another position than shown, the position of the motor terminal box is changed accordingly.

#### Hollow shaft mounted design

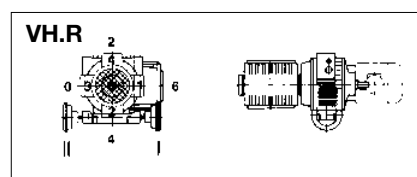
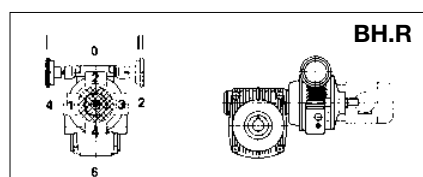
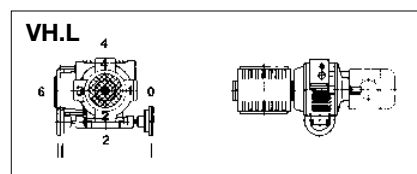
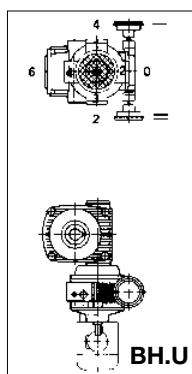
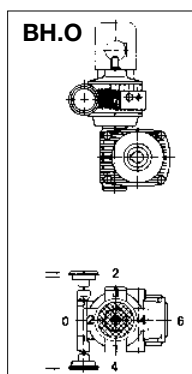
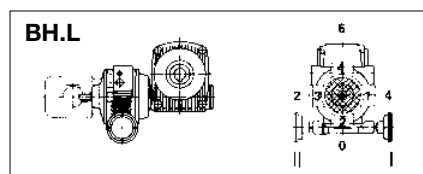

### Mountings

#### Foot-mounted design

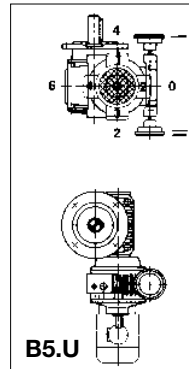
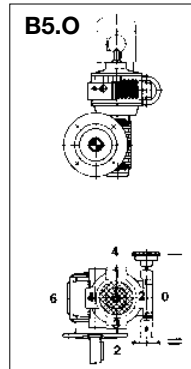
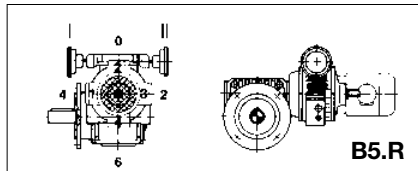
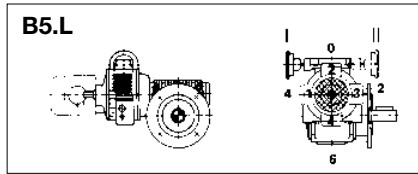

**Attention:** By changing the position of the adjuster device to another position than shown, the position of the motor terminal box is changed accordingly.

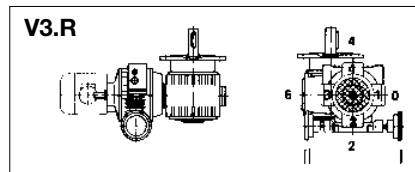
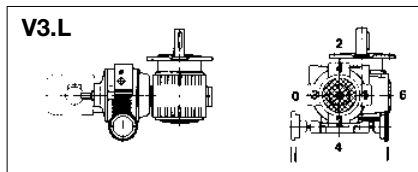
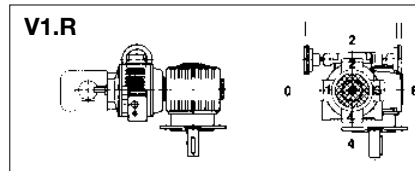
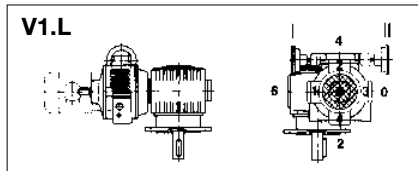

#### Hollow shaft / flange mounted design

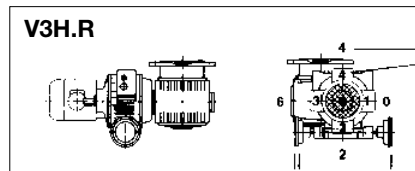
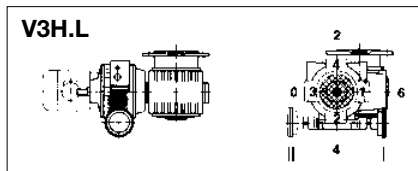
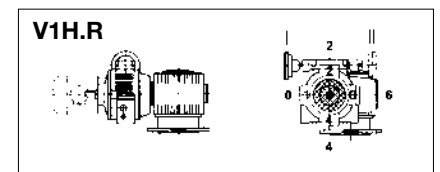
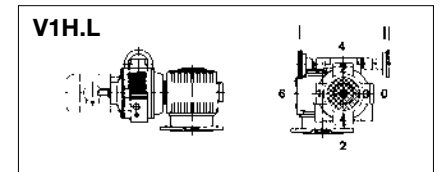
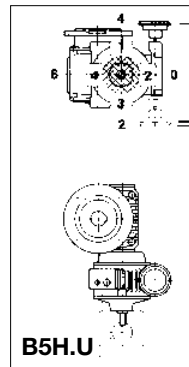
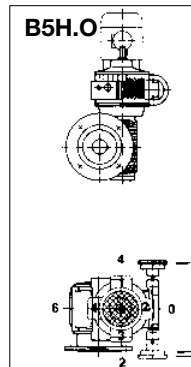
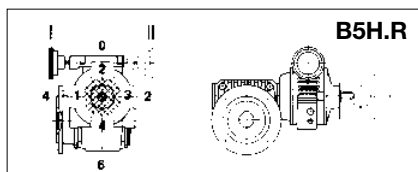
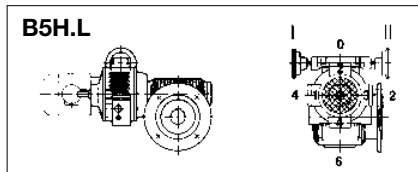

Spindle housing position

Terminal box position

#### Mounting example

Basic design

Spindle housing position

Terminal box position

V3.L.2.2

# DISCO-variable speed drive

## Technical data

### General data

#### Designs

- Input shaft  
Tolerance k6,  
with key to DIN 6885, sheet 1
- Shaft seals  
double lip seals

#### Lubricants

- DISCO-life lubrication oil for ambient temperatures  
 $0^{\circ}\text{C} \leq T_u \leq 40^{\circ}\text{C}$
- Filling quantities  
Factory set according to mounting position  
for filling quantities see "Operating Instructions"

#### Materials

- Housing: aluminium diecast or cast iron according to size
- Input shaft: tempered steel C 45
- Friction parts: roller bearing steel 100 Cr6, hardened
- Shaft seals: NBR/FP

### Mechanical efficiency

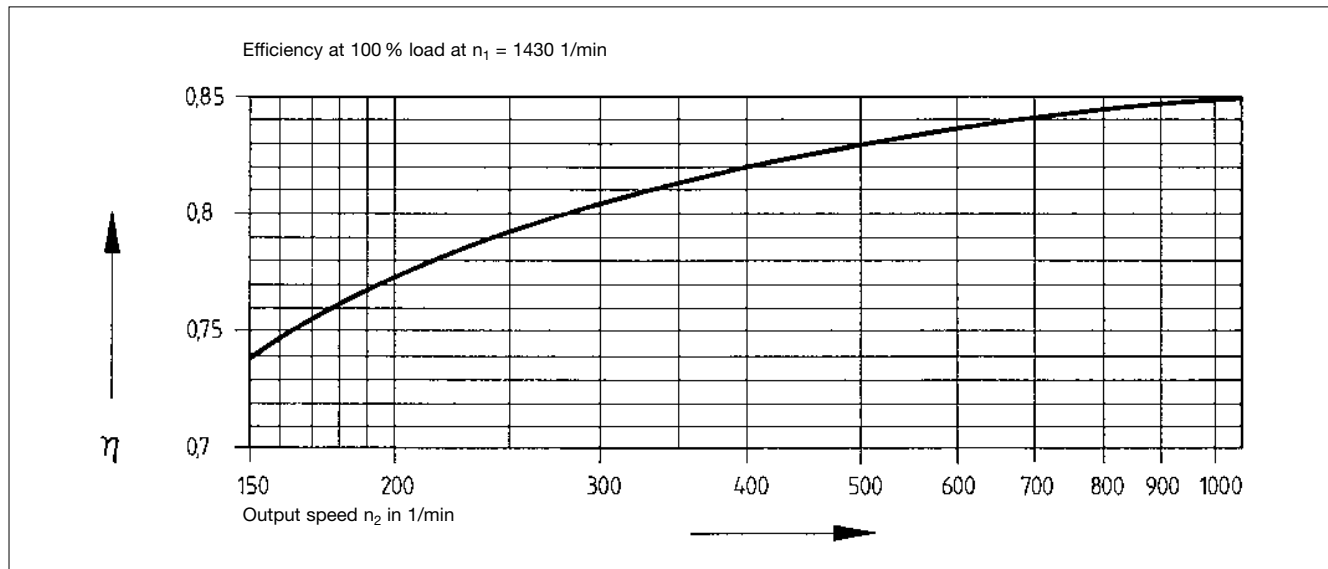

### General data

#### DISCO-specific data

Size		$n_1^*) = 3000$		$n_1 = 1500$		$n_1 = 1000$		$n_1 = 750$	
<b>02</b>	$P_1^*)$ $n_2$ $M_2$	0.37 1860-310 1.6-3.2		0.25 930-155 2-4		0.18 600-100 2-4		0.12 450-75 2-4	
<b>03</b>	$P_1$ $n_2$ $M_2$	0.55 1920-335 2.2-4.4	0.37 1920-335 1.5-4.4	0.37 950-165 3-6		0.25 630-110 3-6		0.18 460-80 3-6	
<b>04</b>	$P_1$ $n_2$ $M_2$	1.1 1920-335 4.5-9	0.75 1920-335 3-9	0.75 950-165 6-12	0.55 950-165 4.5-12	0.55 630-110 6-12	0.37 630-110 4.5-12	0.37 460-80 6-12	0.25 460-80 4.5-12
<b>05</b>	$P_1$ $n_2$ $M_2$	2.2 1920-335 9-18	1.5 1920-335 6-18	1.5 950-165 12-24	1.1 950-165 9-24	1.1 630-110 12-24	0.75 630-110 9-24	0.75 460-80 12-24	0.55 460-80 9-24
<b>06</b>	$P_1$ $n_2$ $M_2$			3 1000-175 22-44	2.2 1000-175 17.5-44	2.2 660-115 22-44	1.5 660-115 17.5-44	1.5 490-85 22-44	1.1 490-85 17.5-44
<b>07</b>	$P_1$ $n_2$ $M_2$			4 1000-175 32-64		3 660-115 32-64		2.2 490-85 32-64	
<b>08/18</b>	$P_1$ $n_2$ $M_2$			7.5 1000-200 58-116	5.5 1000-200 45-90	5.5 660-130 58-116	4 660-130 45-90	4 490-100 58-116	3 490-100 45-90

\*)  $P_1$  = input power in kW  
 $n_1$  = input speed in 1/min  
 $n_2$  = output speed in 1/min  
 $M_2$  = output torque in Nm

#### Maximum input speed $n_1$

Size	02	03	04	05	06	07	08/18
$n_1$ max. (1/min)	3600	3600	3600	1800* 3600	1800	1800	1800

\* free input shaft

#### Permissible radial and axial forces

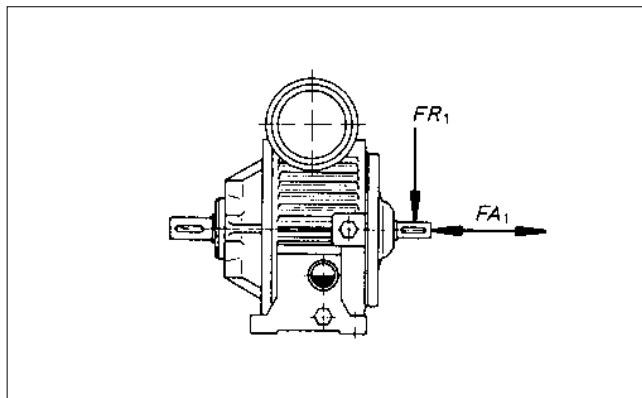

Size	$FA_1$ N	$FR_1$ N
02	300	300
03	450	450
04	700	700
05	1000	1000
06/07	1500	1500
18/08	1800	1800

# DISCO-variable speed drive

## Selection

### Determination of the rated point ( $P_1$ , $M_2$ , $n_2$ )

The rated point results from the maximum drive power required by the whole speed-torque profile. The rated point is at  $n_{2max}$  when the torque requirement

- is constant
- corresponds to the torque characteristic of the DISCO-variable speed drive (see fig.).

Technical notes:

- DISCO-variable speed drives are designed for operation with low switching frequency. For high switching frequencies please contact the manufacturer.
- The torque values  $M_2$  (at  $n_{2min}$ ) indicated in the selection tables can be considerably exceeded under operation with wrong selection.

Rated point  $n_{2max}$  (50 Hz)

Features:

- Large speed setting range  $< = 5...6$
- Good self ventilation of the motor because of constant motor speed at mains frequency.

### Torque characteristic

(under ideal operating conditions)

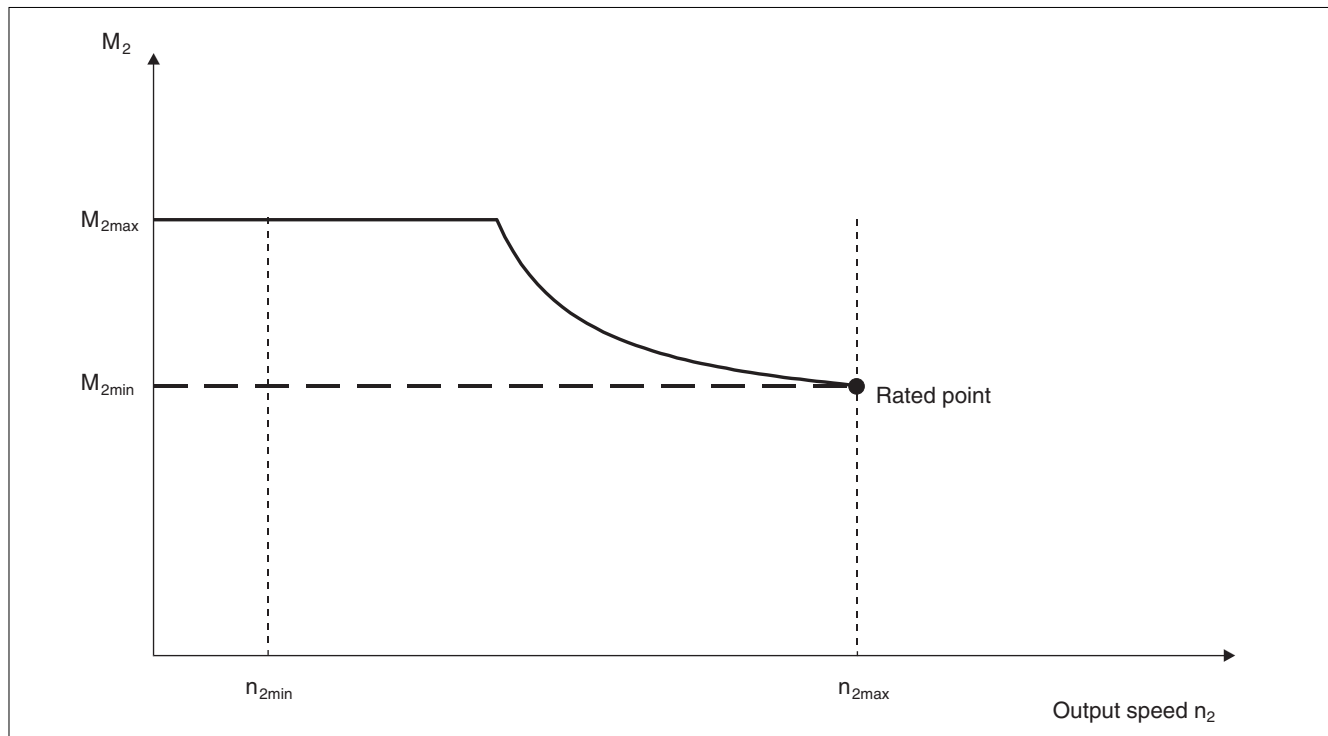



### Determination of the operating factor k

#### Requirements:

- $M_2 \geq M_N \cdot k$   
( $M_2$  from selection tables)

#### 1. Determining the load class from type of input load:

Load class	Type of load and intensity
I	regular operation, virtually shock-free
II	irregular operation, moderate shocks
III	irregular operation, strong shocks and/or changing load

#### 2. Determination of the ambient temperature

#### 3. Read operating factor k from chart

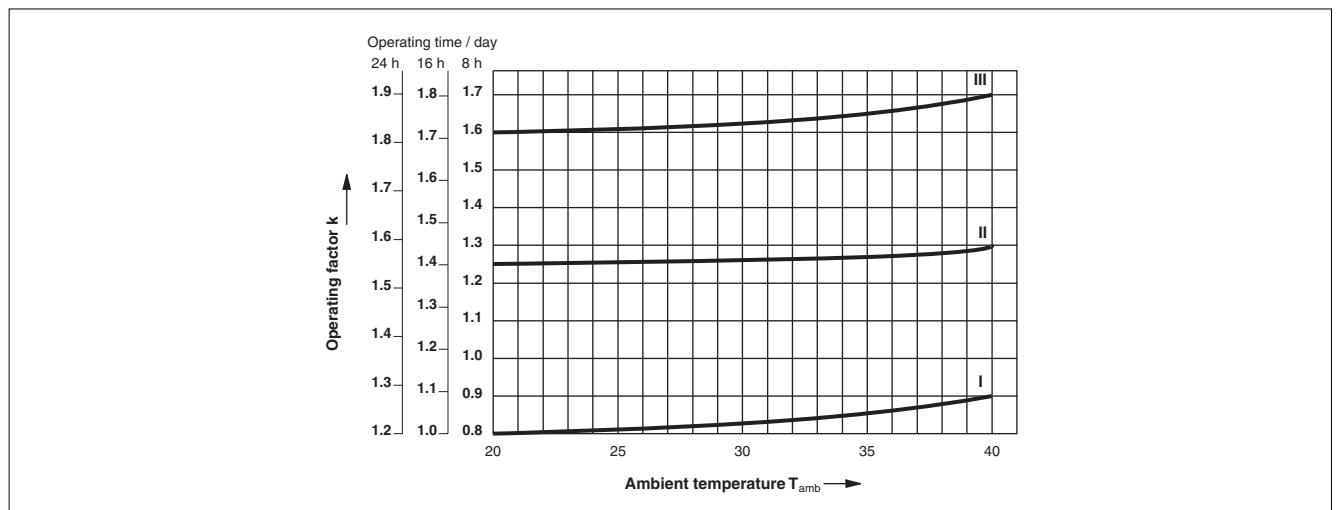

### Determination of the effective forces

#### Requirements:

- $F_{rperm} \geq F_r$   
( $F_{rperm}$  from General data gearbox)

#### 1. Determining the radial force:

- The acting radial forces depend on the application.
- For transmission elements from table: 
$$F_r = \frac{2000 \cdot M_2 \cdot f_z}{d_w}$$

$f_z$	Transmission element
1.12	toothed gears
1.25 ... 1.4	chain wheels
1.5	crown gears
1.5 ... 2.0	small V-belt pulleys depending on initial tension

#### 2. Determining the axial force

- The effective axial forces depend on the application.

# DISCO-variable speed drive

## Drive selection

Selection table

P <sub>1</sub>	n <sub>2</sub> [1/min]	M <sub>2</sub> [Nm]	n <sub>1</sub> [1/min]	i	Type	Dimensions Page	
					0 = free input shaft 1 = direct mounted motor		
<b>0.25 kW</b>	192 – 32	9 – 16	1380	5	11.7□5.02.04	84	
	128 – 21	12 – 23	1380	7	11.7□5.02.04		
	93 – 15	16 – 31	1380	10	11.7□5.02.04		
	71 – 11	20 – 25	1380	13	11.7□5.02.04	84	
	64 – 10	22 – 38	1380	15	11.7□5.02.04		
	46 – 7.8	29 – 45	1380	20	11.7□5.02.04		
	35 – 5.8	37 – 59	1380	26	11.7□5.02.05		
	32 – 5.3	36 – 61	1380	30	11.7□5.02.05	84	
	24 – 4.1	45 – 75	1380	40	11.7□5.02.05		
17 – 2.9	53 – 66	1380	53	11.7□5.02.05			
15 – 2.5	55 – 64	1380	60	11.7□5.02.05	84		
<b>0.37 kW</b>	385 – 64	7 – 13	2840	5		11.7□5.02.04	84
	256 – 42	10 – 18	2840	7		11.7□5.02.04	
	186 – 31	13 – 25	2840	10	11.7□5.02.04		
	143 – 23	17 – 24	2840	13	11.7□5.02.04		
	128 – 21	18 – 32	2840	15	11.7□5.02.04	84	
	93 – 15	24 – 40	2840	20	11.7□5.02.04		
	70 – 11	30 – 53	2840	26	11.7□5.02.05		
	64 – 10	31 – 52	2840	30	11.7□5.02.05		
	48 – 8.2	38 – 64	2840	40	11.7□5.02.05	84	
	35 – 5.8	47 – 57	2840	53	11.7□5.02.05		
	30 – 5.0	48 – 59	2840	60	11.7□5.02.05		
	<b>0.55 kW</b>	397 – 69	7,9 – 18	2840	5		11.7□5.03.04
264 – 46		14 – 26	2840	7	11.7□5.03.04		
192 – 33		19 – 35	2840	10	11.7□5.03.04		
144 – 25		24 – 40	2840	13	11.7□5.03.05		
132 – 23		26 – 46	2840	15	11.7□5.03.05	84	
101 – 17		33 – 58	2840	20	11.7□5.03.05		
72 – 12		42 – 52	2840	26	11.7□5.03.05		
66 – 11		43 – 73	2840	30	11.7□5.03.05		
49 – 8.6		57 – 97	2840	40	11.7□5.03.06	84	
37 – 6.6		70 – 116	2840	53	11.7□5.03.06		
31 – 5.5		73 – 114	2840	60	11.7□5.03.06		
<b>0.75 kW</b>		397 – 69	15 – 38	2810	5		11.7□5.04.05
	264 – 46	22 – 55	2810	7	11.7□5.04.05		
	196 – 34	26 – 49	1380	5	11.7□5.04.05		
	131 – 22	37 – 70	1380	7	11.7□5.04.05		
	100 – 17	48 – 90	1380	10	11.7□5.04.05	84	
	74 – 12	64 – 120	1380	13	11.7□5.04.06		
	65 – 11	69 – 124	1380	15	11.7□5.04.06		
	48 – 8.5	90 – 162	1380	20	11.7□5.04.06		
	37 – 6.5	114 – 188	1380	26	11.7□5.04.06	84	
	32 – 5.7	114 – 192	1380	30	11.7□5.04.06		
	17 – 3.1	195 – 328	1380	53	11.7□5.04.08		
	15 – 2.7	192 – 304	1380	60	11.7□5.04.08		
<b>1.1 kW</b>	397 – 69	20 – 37	2810	5	11.7□5.04.05	84	
	264 – 46	29 – 54	2810	7	11.7□5.04.05		
	202 – 35	37 – 46	2810	10	11.7□5.04.05		
	150 – 26	50 – 93	2810	13	11.7□5.04.06		
	132 – 23	54 – 97	2810	15	11.7□5.04.06	84	
	98 – 17	71 – 127	2810	20	11.7□5.04.06		
	75 – 13	89 – 159	2810	26	11.7□5.04.06		
	66 – 11	92 – 154	2810	30	11.7□5.04.06		
	49 – 8.6	117 – 198	2810	40	11.7□5.04.06	84	
	36 – 6.3	155 – 264	2810	53	11.7□5.04.08		
	31 – 5.4	154 – 251	2810	60	11.7□5.04.08		

Selection table

$P_1$	$n_2$ [1/min]	$M_2$ [Nm]	$n_1$ [1/min]	$i$	Type = free input shaft = direct mounted motor	Dimensions Page		
<b>1.5 kW</b>	397 – 69	27 – 76	2800	5	11.7□5.05.06	84		
	264 – 46	39 – 111	2800	7	11.7□5.05.06			
	196 – 34	52 – 99	1420	5	11.7□5.05.06			
	131 – 22	76 – 143	1420	7	11.7□5.05.06			
	97 – 16	71 – 12	101 – 189	1420	10	11.7□5.05.06	84	
		63 – 11	136 – 254	1420	13	11.7□5.05.08		
		47 – 8.3	147 – 264	1420	15	11.7□5.05.08		
		35 – 6.2	31 – 5.5	190 – 340	1420	20	11.7□5.05.08	84
			23 – 4.1	244 – 395	1420	26	11.7□5.05.08	
			18 – 3.2	248 – 417	1420	30	11.7□5.05.08	
	15 – 2.7	311 – 524	1420	40	11.7□5.05.08			
		397 – 669	1420	53	11.7□5.05.10			
	409 – 649	1420	60	11.7□5.05.10				
<b>2.2 kW**</b>	397 – 69	40 – 76	2800	5	11.7□5.05.06	84		
	264 – 46	59 – 110	2800	7	11.7□5.05.06			
	196 – 34	78 – 146	2800	10	11.7□5.05.06			
	144 – 25	105 – 196	2800	13	11.7□5.05.08			
	128 – 22	96 – 16	113 – 207	2800	15	11.7□5.05.08	84	
		72 – 12	147 – 267	2800	20	11.7□5.05.08		
		64 – 11	190 – 341	2800	26	11.7□5.05.08		
			195 – 335	2800	30	11.7□5.05.08		
	48 – 8.4	37 – 6.5	247 – 421	2800	40	11.7□5.05.08	84	
		30 – 5.4	313 – 540	2800	53	11.7□5.05.10		
			320 – 534	2800	60	11.7□5.05.10		
	<b>3.0 kW</b>	200 – 35	101 – 191	1400	5	11.7□5.06.08	84	
133 – 23		148 – 276	1400	7	11.7□5.06.08			
100 – 17		194 – 361	1400	10	11.7□5.06.08			
75 – 13		251 – 292	1400	13	11.7□5.06.08			
66 – 11		50 – 8.8	271 – 486	1400	15	11.7□5.06.08	84	
		38 – 6.7	359 – 646	1400	20	11.7□5.06.10		
		33 – 5.8	450 – 681	1400	26	11.7□5.06.10		
			473 – 793	1400	30	11.7□5.06.10		
25 – 4.4		19 – 3.4	553 – 1018	1400	40	11.7□5.06.10	84	
		16 – 2.8	766 – 1300	1400	53	11.7□5.06.12		
			800 – 1240	1400	60	11.7□5.06.12		
<b>4.0 kW</b>		200 – 35	149 – 281	1430	5	11.7□5.07.10	84	
	133 – 23	218 – 406	1430	7	11.7□5.07.10			
	100 – 17	286 – 535	1430	10	11.7□5.07.10			
	76 – 13	364 – 527	1430	13	11.7□5.07.10			
	66 – 11	50 – 8.8	402 – 720	1430	15	11.7□5.07.10	84	
		38 – 6.7	522 – 940	1430	20	11.7□5.07.10		
		34 – 6.0	672 – 1207	1430	26	11.7□5.07.12		
			686 – 1151	1430	30	11.7□5.07.12		
	25 – 4.4	19 – 3.4	903 – 1527	1430	40	11.7□5.07.12	84	
			1025 – 1478	1430	53	11.7□5.07.12		
	<b>5.5 kW</b>	207 – 36	203 – 408	1450	5	11.7□5.18.12	84	
		138 – 24	300 – 599	1450	7	11.7□5.18.12		
100 – 17.5		409 – 818	1450	10	11.7□5.18.12			
69 – 12		557 – 1115	1450	15	11.7□5.18.12			
50 – 8.8		755 – 1510	1450	20	11.7□5.18.12			
<b>7.5 kW</b>	207 – 36	262 – 495	1450	5	11.7□5.08.12	84		
	138 – 24	385 – 717	1450	7	11.7□5.08.12			
	100 – 17.5	525 – 975	1450	10	11.7□5.08.12			
	69 – 12	717 – 1275	1450	15	11.7□5.08.12			
	50 – 8.8	965 – 1720	1450	20	11.7□5.08.12			

\*\* not permissible for type 11.705  
with free input shaft at  $n_1 = 2800$  1/min.

# DISCO-variable speed drive

## Drive selection

### Dimensions

#### Type 11.715 Foot-mounted design

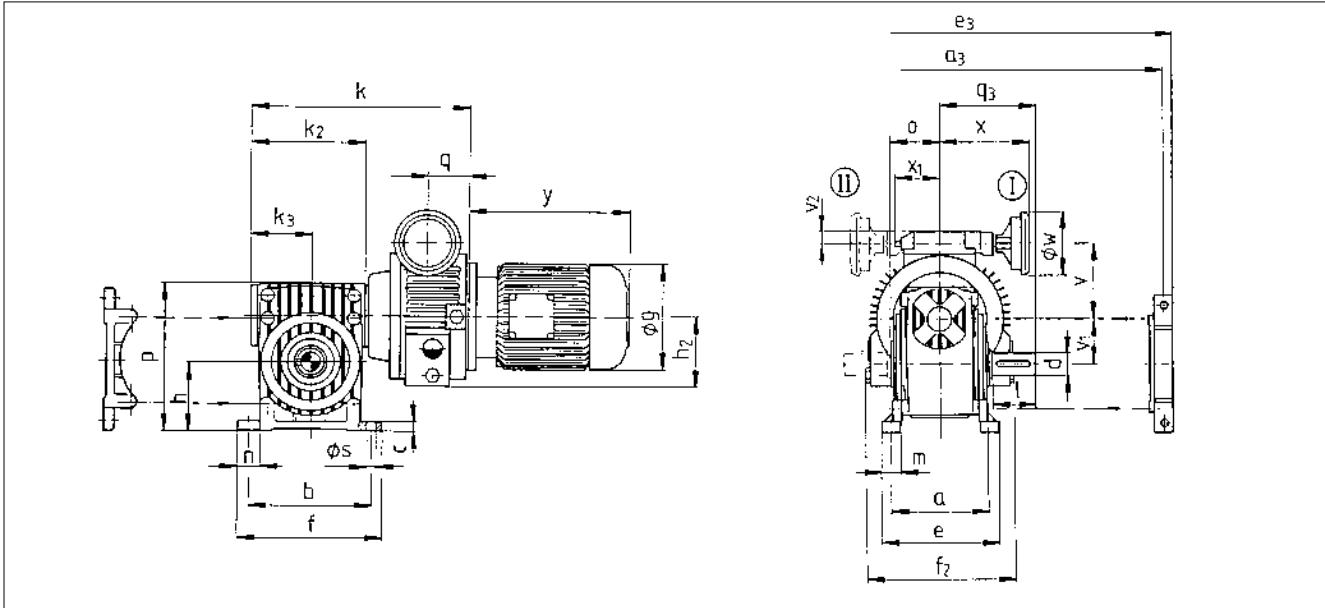

#### Type 11.715 Flange-mounted design

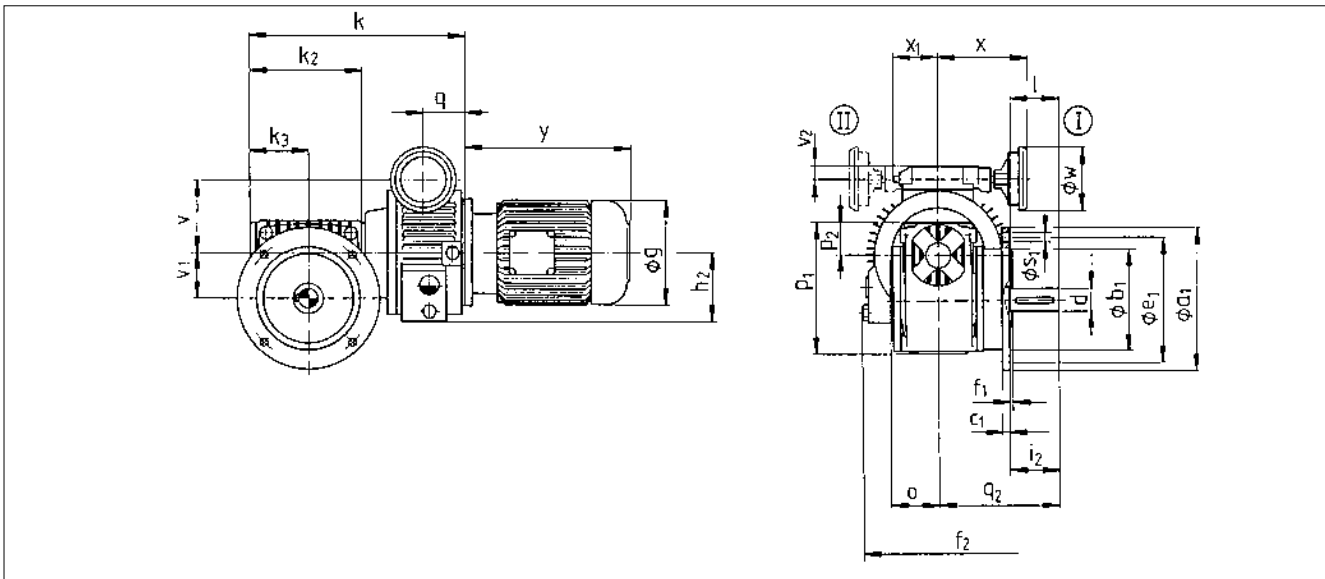

### Dimensions

#### Type 11.715

Typ	a	a <sub>1</sub> <sup>3)</sup>	a <sub>3</sub>	b	b <sub>1</sub> <sup>4)</sup> j7	c	c <sub>1</sub>	d	e	e <sub>1</sub>	e <sub>3</sub>	f	f <sub>1</sub>	f <sub>2</sub>	g <sup>1)</sup>	h	h <sub>2</sub>	h <sub>4</sub>	i <sub>2</sub>	k
11.715.02.04	98	<b>120/140</b>	98	118	80/ 95	11	8	19	122	100/115	122	140	3	150	145	67	65	71	50	221
11.715.02.05	114	<b>140/160</b>	114	152	95/110	14	10	24	146	115/130	146	180	3/3.5	175	145	83	83	83	60	245
11.715.03.04	98	<b>120/140</b>	98	188	80/ 95	11	8	19	122	100/115	122	140	3	175	145	67	83	71	50	251
11.715.03.05	114	<b>140/160</b>	114	152	95/110	14	10	24	146	115/130	146	180	3/3.5	175	145	83	83	83	60	261
11.715.03.06	136	<b>160/200</b>	136	174	110/130	17	12	28	175	130/165	175	205	3.5	205	100	100	100	70	289	
11.715.04.05	114	<b>140/160</b>	114	152	95/110	14	10	24	146	115/130	146	180	3/3.5	215	160	83	98	83	60	280
11.715.04.06	136	<b>160/200</b>	136	174	110/130	17	12	28	175	130/165	175	205	3.5	215	160	100	98	100	70	308
11.715.04.08	166	<b>200/250</b>	166	212	130/180	19	14	38	200	165/215	200	245	3.5/4	245	180	121	121	121	80	351
11.715.05.06	136	<b>160/200</b>	136	174	110/130	17	12	28	175	130/165	175	205	3.5	253	180	100	122	100	70	330
11.715.05.08	166	<b>200/250</b>	166	212	130/180	19	14	38	200	165/215	200	245	3.5/4	253	180	121	122	121	80	373
11.715.05.10	194	<b>250/300</b>	194	240	180/230	22	16	48	234	215/265	234	280	4	280	200	150	150	150	100	409
11.715.06.08	166	<b>200/250</b>	166	212	130/180	19	14	38	200	165/215	200	245	3.5	305	200	121	145	121	80	387
11.715.06.10	194	<b>250/300</b>	194	240	180/230	22	16	48	234	215/265	234	280	4	305	200	150	145	150	100	429
11.715.06.12	235	<b>300/350</b>	235	300	230/250	25	20	55	286	265/300	286	350	4/5	350	200	186	186	186	110	506
11.715.07.10	194	<b>250/300</b>	194	240	180/230	22	16	48	234	215/265	234	280	4	305	225	150	145	150	100	429
11.715.07.12	235	<b>300/350</b>	235	300	230/250	25	20	55	286	265/300	286	350	4/5	305	225	186	145	186	110	506
11.715.08.12	235	<b>300/350</b>	235	300	230/250	25	20	55	286	265/300	286	350	4/5	379	265	186	176	186	110	522
11.715.18.12	235	<b>300/350</b>	235	300	230/250	25	20	55	286	265/300	286	350	4/5	379	265	186	176	186	110	522

Type	k <sub>2</sub>	k <sub>3</sub>	l	m	n	o	p	p <sub>1</sub>	p <sub>2</sub>	q	q <sub>2</sub>	q <sub>3</sub>	s	s <sub>1</sub>	v	v <sub>1</sub>	v <sub>2</sub>	w	x	x <sub>1</sub>	y <sup>1)</sup>	m <sup>1)</sup> [kg]
11.715.02.04	121	65	50	21	35	49	145	128	38	42	122	100	10	6.6/9	83	40	14	70	105	43	215	20
11.715.02.05	136	73	60	27	44	59	175	153	41	50	149	120	10	9	83	50	14	70	105	43	215	23
11.715.03.04	121	65	50	21	35	49	145	128	38	50	122	100	10	6.6/9	86	40	14	70	105	43	215	28
11.715.03.05	136	73	60	27	44	59	175	153	41	50	149	120	10	9	86	50	14	70	105	43	215	32
11.715.03.06	166	88	70	32	48	67	215	190	52	52	172	140	12	9/11	86	63	14	70	105	43	215	40
11.715.04.05	136	73	60	27	44	59	175	153	41	58	149	120	10	9	103	50	17	105	152	63	235	43
11.715.04.06	166	88	70	32	48	67	215	190	52	58	172	140	12	9/11	103	63	17	105	152	63	235	51
11.715.04.08	195	103	80	32	58	82	258	228	57	57	207	165	14	11/14	103	80	17	105	152	63	235	65
11.715.05.06	166	88	70	32	48	67	215	190	52	74	172	140	12	9/11	123	63	17	105	152	63	285	71
11.715.05.08	195	103	80	32	58	82	258	228	57	74	207	165	14	11/14	123	80	17	105	152	63	285	85
11.715.05.10	224	118	100	40	63	87	315	275	65	74	234	190	18	14	100	100	17	105	152	63	320	107
11.715.06.08	195	103	80	32	58	82	258	228	57	82	207	165	14	11/14	149	80	17	105	152	63	320	118
11.715.06.10	224	118	100	40	63	87	315	275	65	82	234	190	18	14	100	100	17	105	152	63	320	140
11.715.06.12	277	146	110	48	67	105	385	340	74	82	272	218	22	14/18	125	125	17	105	152	63	340	174
11.715.07.10	224	118	100	40	63	87	315	275	65	82	234	190	18	14	100	100	17	105	152	63	340	150
11.715.07.12	277	146	110	48	67	105	385	340	74	82	272	218	22	14/18	125	125	17	105	152	63	340	186
11.715.08.12	277	146	110	48	67	105	385	340	74	104	272	218	22	14/18	190	125	26	160	195 <sup>2)</sup>	111	415	251
11.715.18.12	277	146	110	48	67	105	385	340	74	104	272	218	22	14/18	190	125	26	160	195 <sup>2)</sup>	111	415	251

1) Deviations in motor dimensions possible

2) Add. hand lever 80 mm

3) Bold print = standard

4) ISO-tolerance h7 for b1 over 230 mm

Shafts: ISO-tolerance up to Ø 50 mm = k6

ISO-tolerance over Ø 50 mm = m6

Keys to DIN 6885/1

Tapped shaft ends to DIN 332-DR

Dimensions in [mm]

# DISCO-variable speed drive

## Drive selection

### Dimensions

#### Type 11.715 Hollow shaft-mounted design

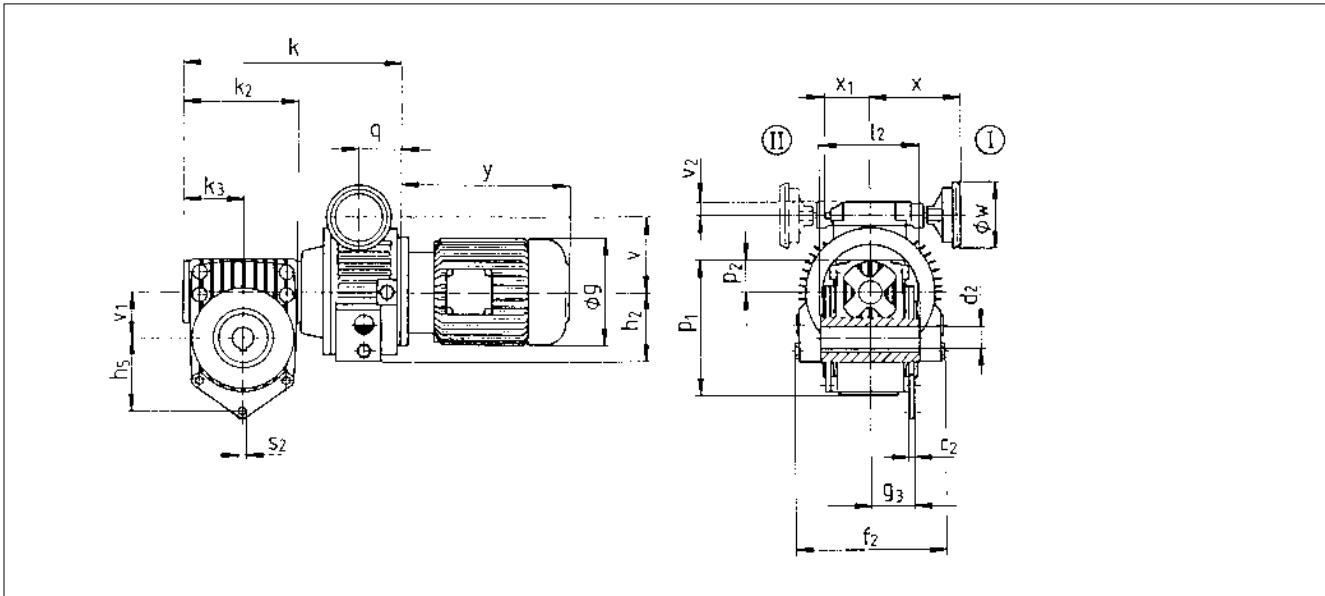

#### Type 11.715 Flange-hollow shaft-mounted design

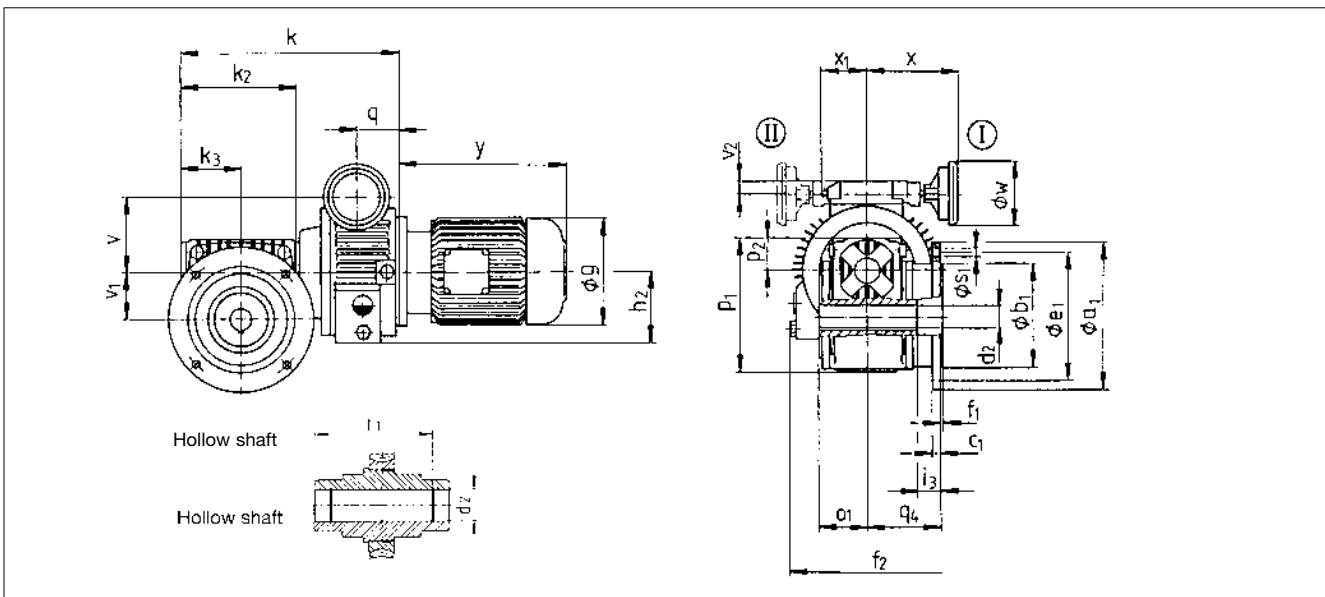

### Dimensions

#### Type 11.715

Typ	a <sub>1</sub> <sup>3)</sup>	b <sub>1</sub> <sup>4)</sup> j7	c <sub>1</sub>	c <sub>2</sub>	d <sub>2</sub> H7	e <sub>1</sub>	f <sub>1</sub>	f <sub>2</sub>	g <sup>1)</sup>	g <sub>3</sub>	h <sub>2</sub>	h <sub>5</sub>	i <sub>3</sub>	k
11.715.02.04 11.715.02.05	120/ <b>140</b> 140/ <b>160</b>	80/ 95 95/110	8 10	5 6	20 25	100/115 115/130	3 3/3.5	150	145	43 50	65	69 82	29 38.5	221 245
11.715.03.04 11.715.03.05 11.715.03.06	120/ <b>140</b> 140/ <b>160</b> 160/ <b>200</b>	80/ 95 95/110 110/130	8 10 12	5 6 6	20 25 30	100/115 115/130 130/165	3 3/3.5 3.5	175	145	43 50 59	83	69 82 97	29 38.5 39.5	251 261 289
11.715.04.05 11.715.04.06 11.715.04.08	140/ <b>160</b> 160/ <b>200</b> 200/ <b>250</b>	95/110 110/130 130/180	10 12 14	6 6 6	25 30 40	115/130 130/165 165/215	3/3.5 3.5 3.5/4	215	160	50 59 71	98	82 97 114	38.5 39.5 53.5	280 308 351
11.715.05.06 11.715.05.08 11.715.05.10	160/ <b>200</b> 200/ <b>250</b> 250/ <b>300</b>	110/130 130/180 180/230	12 14 16	6 6 6	30 40 50	130/165 165/215 215/265	3.5 3.5/4 4	253	180	59 71 75	122	97 114 138	39.5 53.5 58.5	330 373 409
11.715.06.08 11.715.06.10 11.715.06.12	200/ <b>250</b> 250/ <b>300</b> 300/ <b>350</b>	130/180 180/230 230/250	14 16 20	6 6 6	40 50 70	165/215 215/265 265/300	3.5 4 4/5	305	200	71 75 93	145	114 138 167	53.5 58.5 67.5	387 429 506
11.715.07.10 11.715.07.12	250/ <b>300</b> 300/ <b>350</b>	180/230 230/250	16 20	6 6	50 70	215/265 265/300	4 4/5	305	225	75 93	145	138 167	58.5 67.5	429 506
11.715.08.12 11.715.18.12	300/ <b>350</b> 300/ <b>350</b>	230/250 230/250	20 20	6 6	70 70	265/300 265/300	4/5 4/5	379	265	93 93	176	167 167	67.5 67.5	522 522

Type	k <sub>2</sub>	k <sub>3</sub>	l <sub>2</sub>	o <sub>1</sub>	p <sub>1</sub>	p <sub>2</sub>	q	q <sub>4</sub>	s <sub>1</sub>	s <sub>2</sub>	t <sub>1</sub>	v	v <sub>1</sub>	v <sub>2</sub>	w	x	x <sub>1</sub>	y <sup>1)</sup>	m <sup>1)</sup> [kg]
11.715.02.04 11.715.02.05	121 136	65 73	100 120	50 60	128 153	38 41	42	79 99	6.6/9 9	10.5 12.5	87 104	83	40 50	14	70	105	43	215	20 23
11.715.03.04 11.715.03.05 11.715.03.06	121 136 166	65 73 88	100 120 140	50 60 70	128 153 190	38 41 52	50	79 99 110	6.6/9 9 9/11	10.5 12.5 16.5	87 104 122	86	40 50 63	14	70	105	43	215	28 32 40
11.715.04.05 11.715.04.06 11.715.04.08	136 166 195	73 88 103	120 140 170	60 70 85	153 190 228	41 52 57	58	99 110 139	9 9/11 11/14	12.5 16.5 16.5	104 122 148	103	50 63 80	17	105	152	63	235	43 51 65
11.715.05.06 11.715.05.08 11.715.05.10	166 195 224	88 103 118	140 170 180	70 85 90	190 228 275	52 57 65	74	110 139 149	9/11 11/14 14	16.5 16.5 20.5	122 148 154	123	63 80 100	17	105	152	63	285	71 85 107
11.715.06.08 11.715.06.10 11.715.06.12	195 224 277	103 118 146	170 180 215	85 90 108	228 275 340	57 65 74	82	139 149 175	11/14 14 14/18	16.5 20.5 20.5	148 154 187	149	80 100 125	17	105	152	63	320	118 140 174
11.715.07.10 11.715.07.12	224 277	118 146	180 215	90 108	275 340	65 74	82	149 175	14 14/18	20.5 20.5	154 187	149	100 125	17	105	152	63	340	150 186
11.715.08.12 11.715.18.12	277 277	146 146	215 215	108 108	340 340	74 74	104	175 175	14/18 14/18	20.5 20.5	187 187	190	125 125	26	160	195 <sup>5)</sup>	111	415	251 251

1) Deviations in motor dimensions possible

2) Add. hand lever 80 mm

3) Bold print = standard

4) ISO-tolerance h7 for b1 over 230 mm

Keys to DIN 6885/1

Dimensions in [mm]

# DISCO-variable speed drive

## Drive selection

### Dimensions

#### Type 11.705 Foot-mounted design

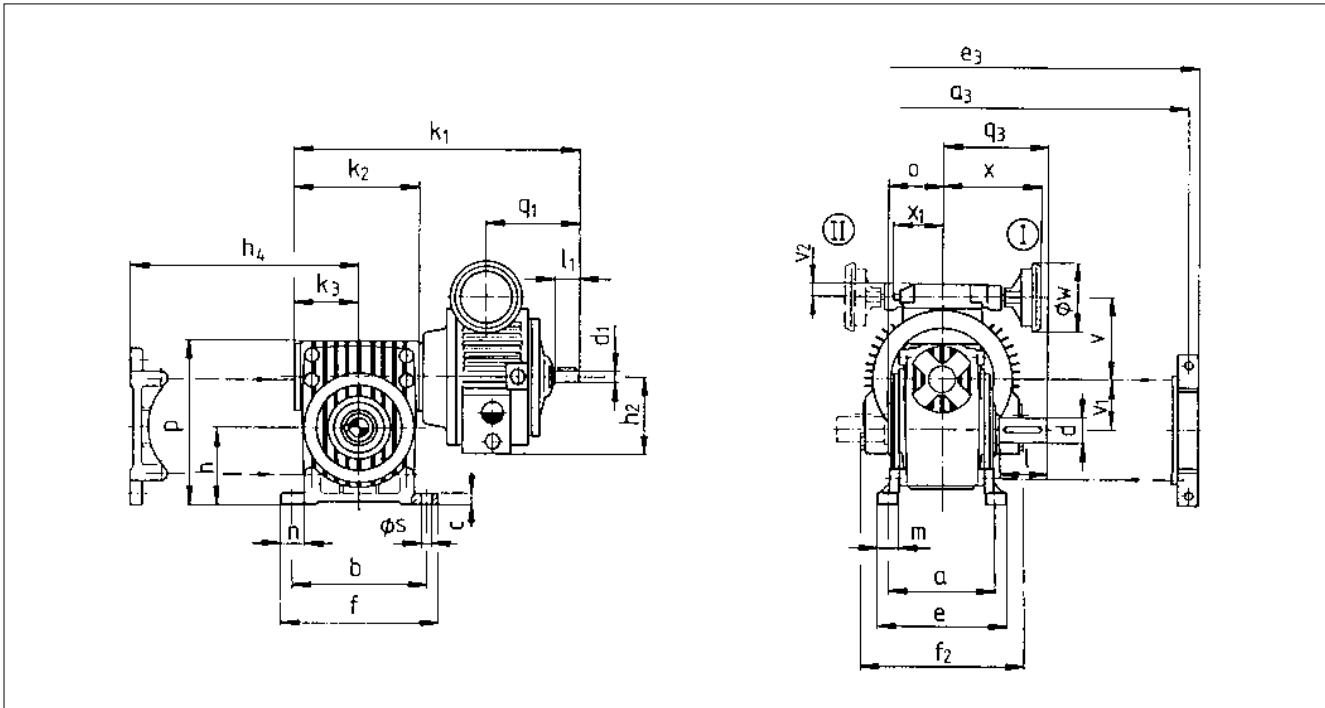

#### Type 11.705 Flange-mounted design

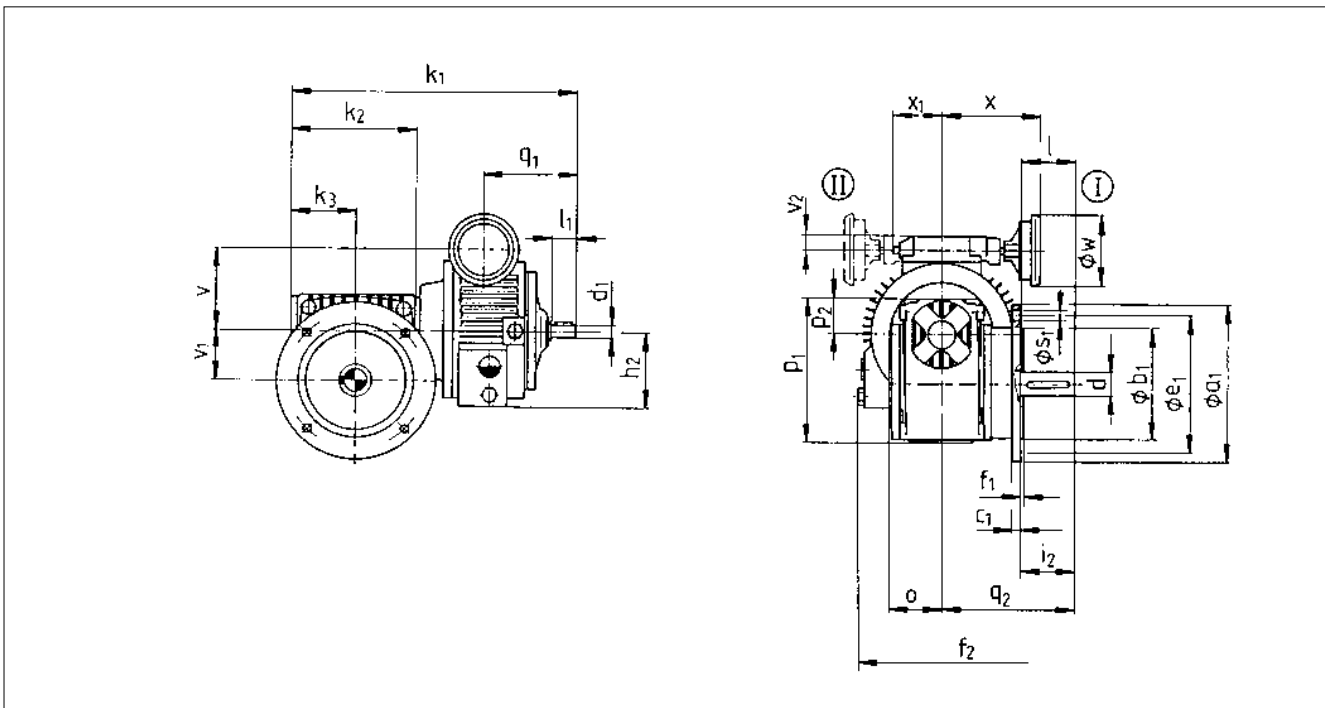



### Dimensions

#### Type 11.705

Type	a	a <sub>1</sub> <sup>3)</sup>	a <sub>3</sub>	b	b <sub>1</sub> <sup>4)</sup> j7	c	c <sub>1</sub>	d	d <sub>1</sub>	e	e <sub>1</sub>	e <sub>3</sub>	f	f <sub>1</sub>	f <sub>2</sub>	h	h <sub>2</sub>	h <sub>4</sub>	i <sub>2</sub>	k <sub>1</sub>
11.705.02.04	98	120/140	98	118	80/ 95	11	8	19	11	122	100/115	122	140	3	150	67	65	71	50	273
11.705.02.05	114	140/160	114	152	95/110	14	10	24	11	146	115/130	146	180	3/3.5	150	84	83	83	60	297
11.705.03.04	98	120/140	98	188	80/ 95	11	8	19	14	122	100/115	122	140	3	175	67	83	71	50	312
11.705.03.05	114	140/160	114	152	95/110	14	10	24	14	146	115/130	146	180	3/3.5	175	86	83	83	60	322
11.705.03.06	136	160/200	136	174	110/130	17	12	28	14	175	130/165	175	205	3/5	100	100	100	70	350	
11.705.04.05	114	140/160	114	152	95/110	14	10	24	15	146	115/130	146	180	3/3.5	215	86	98	83	60	333
11.705.04.06	136	160/200	136	174	110/130	17	12	28	15	175	130/165	175	205	3.5	100	100	100	70	361	
11.705.04.08	166	200/250	166	212	130/180	19	14	38	15	200	165/215	200	245	3.5/4	121	121	121	80	404	
11.705.05.06	136	160/200	136	174	110/130	17	12	28	20	175	130/165	175	205	3.5	253	100	122	100	70	403
11.705.05.08	166	200/250	166	212	130/180	19	14	38	20	200	165/215	200	245	3.5/4	121	121	121	80	446	
11.705.05.10	194	250/300	194	240	180/230	22	16	48	20	234	215/265	234	280	4	150	150	150	100	483	
11.705.06.08	166	200/250	166	212	130/180	19	14	38	25	200	165/215	200	245	3.5/4	305	121	145	121	80	490
11.705.06.10	194	250/300	194	240	180/230	22	16	48	25	234	215/265	234	280	4	150	150	150	100	532	
11.705.06.12	235	300/350	235	300	230/250	25	20	55	25	286	265/300	286	350	4/5	186	186	186	110	609	
11.705.07.10	194	250/300	194	240	180/230	22	16	48	25	234	215/265	234	280	4	305	150	145	150	100	532
11.705.07.12	235	300/350	235	300	230/250	25	20	55	25	286	265/300	286	350	4/5	305	186	145	186	110	609
11.705.08.12	235	300/350	235	300	230/250	25	20	55	25	286	265/300	286	350	4/5	379	186	176	186	110	674
11.705.18.12	235	300/350	235	300	230/250	25	20	55	25	286	265/300	286	350	4/5	379	186	176	186	110	674

Type	k <sub>2</sub>	k <sub>3</sub>	l	l <sub>1</sub>	m	n	o	p	p <sub>1</sub>	p <sub>2</sub>	q <sub>1</sub>	q <sub>2</sub>	q <sub>3</sub>	s	s <sub>1</sub>	v	v <sub>1</sub>	v <sub>2</sub>	w	x	x <sub>1</sub>	m [kg]
11.705.02.04	121	65	50	23	21	35	49	145	128	38	94	122	100	10	6.6/9	83	40	14	70	105	43	12
11.705.02.05	136	73	60	23	27	44	59	175	153	41	94	149	120	10	9	83	50	14	70	105	43	16
11.705.03.04	121	65	50	30	21	35	49	145	128	38	112	122	100	10	6.6/9	86	40	14	70	105	43	21
11.705.03.05	136	73	60	30	27	44	59	175	153	41	112	149	120	10	9	86	50	14	70	105	43	25
11.705.03.06	166	88	70	30	32	48	67	215	190	52	112	172	140	12	9/11	86	63	14	70	105	43	33
11.705.04.05	136	73	60	30	27	44	59	175	153	41	112	149	120	10	9	103	50	17	105	152	63	33
11.705.04.06	166	88	70	30	32	48	67	215	190	52	112	172	140	12	9/11	103	63	17	105	152	63	41
11.705.04.08	195	103	80	30	32	58	82	258	228	57	112	207	165	14	11/14	103	80	17	105	152	63	55
11.705.05.06	166	88	70	40	32	48	67	215	190	52	147	172	140	12	9/11	123	63	17	105	152	63	55
11.705.05.08	195	103	80	40	32	58	82	258	228	57	147	207	165	14	11/14	123	80	17	105	152	63	69
11.705.05.10	224	118	100	40	40	63	87	315	275	65	147	234	190	18	14	123	100	17	105	152	63	91
11.705.06.08	195	103	80	50	32	58	82	258	228	57	186	207	165	14	11/14	149	80	17	105	152	63	92
11.705.06.10	224	118	100	50	40	63	87	315	275	65	186	234	190	18	14	149	100	17	105	152	63	114
11.705.06.12	277	146	110	50	48	67	105	385	340	74	186	272	218	22	14/18	149	125	26	160	195 <sup>2)</sup>	111	150
11.705.07.10	224	118	100	50	40	63	87	315	275	65	186	234	190	18	14	149	100	17	105	152	63	114
11.705.07.12	277	146	110	50	48	67	105	385	340	74	186	272	218	22	14/18	149	125	26	160	195 <sup>2)</sup>	111	150
11.705.08.12	277	146	110	50	48	67	105	385	340	74	256	272	218	22	14/18	190	125	26	160	195 <sup>2)</sup>	111	202
11.705.18.12	277	146	110	50	48	67	105	385	340	74	256	272	218	22	14/18	190	125	26	160	195 <sup>2)</sup>	111	202

2) Add. hand lever 80 mm

3) Bold print = standard

4) ISO-tolerance h7 for b1 over 230 mm

Shafts: ISO-tolerance up to Ø 50 mm = k6

ISO-tolerance over Ø 50 mm = m6

Keys to DIN 6885/1

Tapped shaft ends to DIN 332-DR

Dimensions in [mm]

# DISCO-variable speed drive

## Drive selection

### Dimensions

#### Type 11.705 Hollow shaft-mounted design

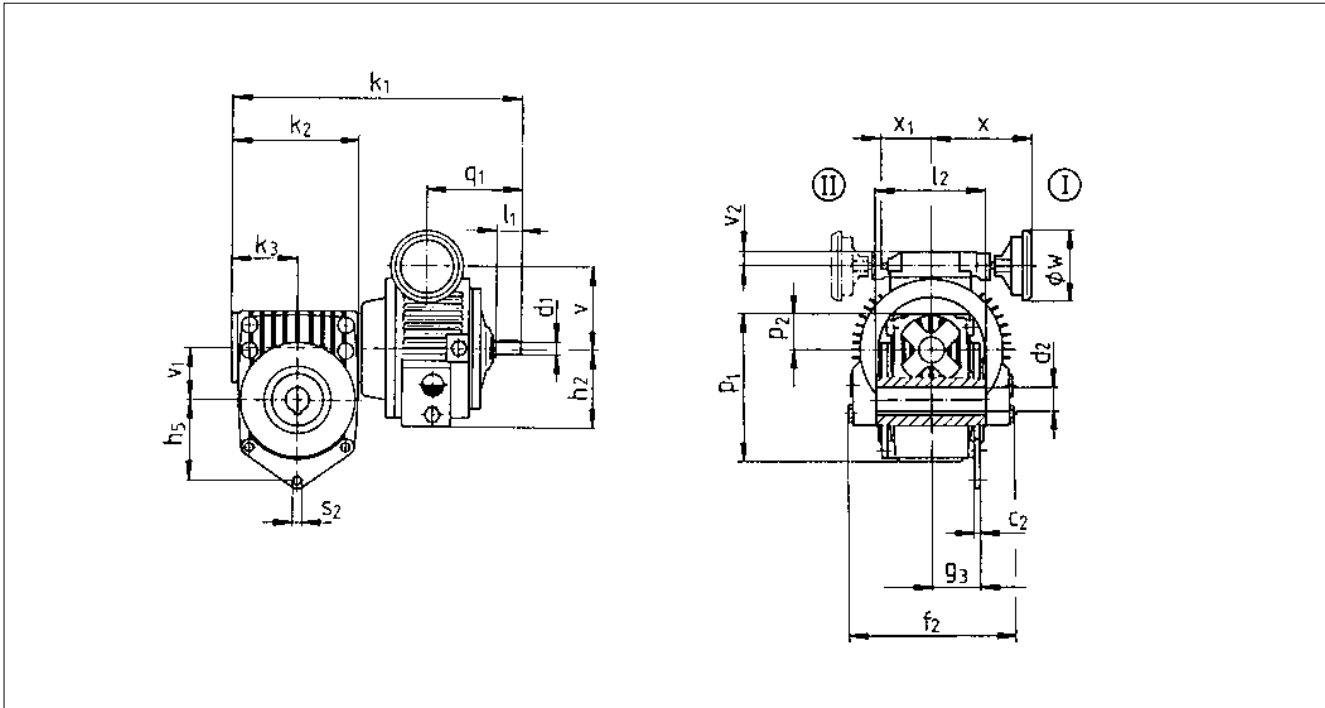

#### Type 11.705 Flange-hollow shaft-mounted design

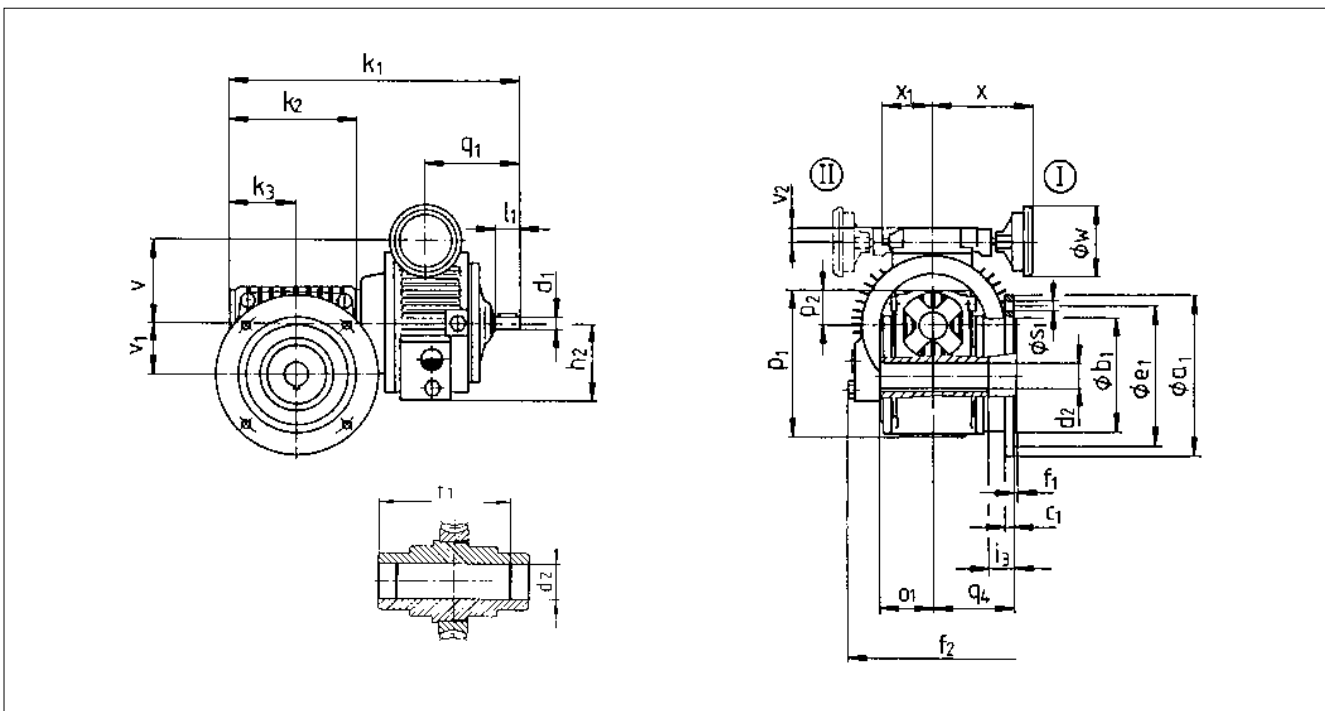

### Dimensions

#### Type 11.705

Type	a <sub>1</sub> <sup>3)</sup>	b <sub>1</sub> <sup>4)</sup> j7	c <sub>1</sub>	c <sub>2</sub>	d <sub>1</sub>	d <sub>2</sub> H7	e <sub>1</sub>	f <sub>1</sub>	f <sub>2</sub>	g <sub>3</sub>	h <sub>2</sub>	h <sub>5</sub>	i <sub>3</sub>	k <sub>1</sub>				
11.705.02.04	120/ <b>140</b>	80/ 95	8	5	11	20	100/115	3	150	43	65	69	29	273				
11.705.02.05	140/ <b>160</b>	95/110	10	6		25	115/130	3/3.5							50	82	38.5	297
11.705.03.04	120/ <b>140</b>	80/ 95	8	5	14	20	100/115	3	175	43	83	69	29	312				
11.705.03.05	140/ <b>160</b>	95/110	10	6		25	115/130	3/3.5							50	82	38.5	322
11.705.03.06	160/ <b>200</b>	110/130	12	6		30	130/165	3.5							59	97	39.5	350
11.705.04.05	140/ <b>160</b>	95/110	10	6	15	25	115/130	3/3.5	215	50	98	82	38.5	333				
11.705.04.06	160/ <b>200</b>	110/130	12	6		30	130/165	3.5							59	97	39.5	361
11.705.04.08	200/ <b>250</b>	130/180	14	6		40	165/215	3.5/4							71	114	53.5	404
11.705.05.06	160/ <b>200</b>	110/130	12	6	20	30	130/165	3.5	253	59	122	97	39.5	403				
11.705.05.08	200/ <b>250</b>	130/180	14	6		40	165/215	3.5/4							71	114	53.5	446
11.705.05.10	250/ <b>300</b>	180/230	16	6		50	215/265	4							75	138	58.5	483
11.705.06.08	200/ <b>250</b>	130/180	14	6	25	40	165/215	3.5	305	71	145	114	53.5	490				
11.705.06.10	250/ <b>300</b>	180/230	16	6		50	215/265	4							75	138	58.5	532
11.705.06.12	300/ <b>350</b>	230/250	20	6		70	265/300	4/5							93	167	67.5	609
11.705.07.10	250/ <b>300</b>	180/230	16	6	25	50	215/265	4	305	75	145	138	58.5	532				
11.705.07.12	300/ <b>350</b>	230/250	20	6		70	265/300	4/5							93	167	67.5	609
11.705.08.12	300/ <b>350</b>	230/250	20	6	25	70	265/300	4/5	379	93	176	167	67.5	674				
11.705.18.12	300/ <b>350</b>	230/250	20	6		70	265/300	4/5							93	167	67.5	674

Type	k <sub>2</sub>	k <sub>3</sub>	l <sub>1</sub>	l <sub>2</sub>	o <sub>1</sub>	p <sub>1</sub>	p <sub>2</sub>	q <sub>1</sub>	q <sub>4</sub>	s <sub>1</sub>	s <sub>2</sub>	t <sub>1</sub>	v	v <sub>1</sub>	v <sub>2</sub>	w	x	x <sub>1</sub>	m [kg]		
11.705.02.04	121	65	23	100	50	128	38	94	79	6.6/9	10.5	87	83	40	14	70	105	43	12		
11.705.02.05	136	73		120	60	153	41		99	9	12.5	104		104						50	16
11.705.03.04	121	65	30	100	50	128	38	112	79	6.6/9	10.5	87	86	40	14	70	105	43	21		
11.705.03.05	136	73		120	60	153	41		99	9	12.5	104		104						50	25
11.705.03.06	166	88		140	70	190	52		110	9/11	16.5	122		122						63	33
11.705.04.05	136	73	30	120	60	153	41	112	99	9	12.5	104	103	50	17	105	152	63	33		
11.705.04.06	166	88		140	70	190	52		110	9/11	16.5	122		122						63	41
11.705.04.08	195	103		170	85	228	57		139	11/14	16.5	148		148						80	55
11.705.05.06	166	88	40	140	70	190	52	147	110	9/11	16.5	122	123	63	17	105	152	63	55		
11.705.05.08	195	103		170	85	228	57		139	11/14	16.5	148		148						80	69
11.705.05.10	224	118		180	90	275	65		149	14	20.5	154		154						100	91
11.705.06.08	195	103	50	170	85	228	57	186	139	11/14	16.5	148	149	80	17	105	152	63	92		
11.705.06.10	224	118		180	90	275	65		149	14	20.5	154		149						100	114
11.705.06.12	277	146		215	108	340	74		175	14/18	20.5	187		187						125	150
11.705.07.10	224	118	50	180	90	275	65	186	149	14	20.5	154	149	100	17	105	152	63	114		
11.705.07.12	277	146		215	108	340	74		175	14/18	20.5	187		187						125	150
11.705.08.12	277	146	50	215	108	340	74	256	175	14/18	20.5	187	190	125	26	160	195 <sup>2)</sup>	111	202		
11.705.18.12	277	146		215	108	340	74		175	14/18	20.5	187		187						125	202

<sup>2)</sup> Add. hand lever 80 mm

<sup>3)</sup> Bold print = standard

<sup>4)</sup> ISO-tolerance h7 for b1 over 230 mm

Keys to DIN 6885/1

Tapped shaft ends to DIN 332-DR

Dimensions in [mm]

# DISCO-variable speed drive

## Drive selection

### Options – Speed-adjustment units

#### Executions

Name	Hand wheel adjuster (Standard)	Bevel gear adjuster (Option)	Electrical adjuster (Option)
Installation	Hand wheel – impact-resistant plastic	Hand wheel – impact-resistant plastic	Servo motor – three-phase AC asynchronous motor – for technical data see below
Position indication	– parallel axial to axis of spindle	– rectangular to axis of spindle	– rectangular to axis of spindle
Position indication in hand wheel	Option – for scaling see below	Option – for scaling see below	

#### Technical data: servo motor (for electrical remote adjuster)

Disco Size	P <sub>1</sub> [kW]	N <sub>1</sub> [1/min]	Voltage/frequency [V]	Rated current [I]	Enclosure	Thermal class	Ratio small gearbox	Adjustment time [s]
02	0.012	1350	Δ 220–240 V/50 HZ Y 380–415 V/50 HZ	0.18 0.1	IP 54	F	20 60	10 30
03	0.012	1350	Δ 220–240 V/50 HZ Y 380–415 V/50 HZ	0.18 0.1	IP 54	F	20 60	13 40
04	0.060	1350	Δ 220–240 V/50 HZ Y 380–415 V/50 HZ	0.4 0.23	IP 54	F	20 55	15 40
05	0.060	1350	Δ 220–240 V/50 HZ Y 380–415 V/50 HZ	0.4 0.23	IP 54	F	20 55	17 47
06/07	0.060	1350	Δ 220–240 V/50 HZ Y 380–415 V/50 HZ	0.4 0.23	IP 54	F	20 55	19 47
08	0.18	1350	Δ 220–240 V/50 HZ Y 380–415 V/50 HZ	0.94 0.55	IP 54	F	40 80	50 100

#### Output speed variations for DISCO sizes 06 . . . 18/08 with electrical adjuster

DISCO Size	Input speed n <sub>1</sub> [1/min]		
	1500	1000	750
	Output speed n <sub>2</sub> [1/min]		
06/07	980–190	645–125	480–95
18/08	965–220	635–145	475–110

#### Position indicator in hand wheel: scaling

DISCO Size	02	03	04/05	06/07	18/08
Scaling	12	18	24	24	36

### Options – Speed-adjustment units

#### Spindle housing

#### Standard design for hand wheel adjuster

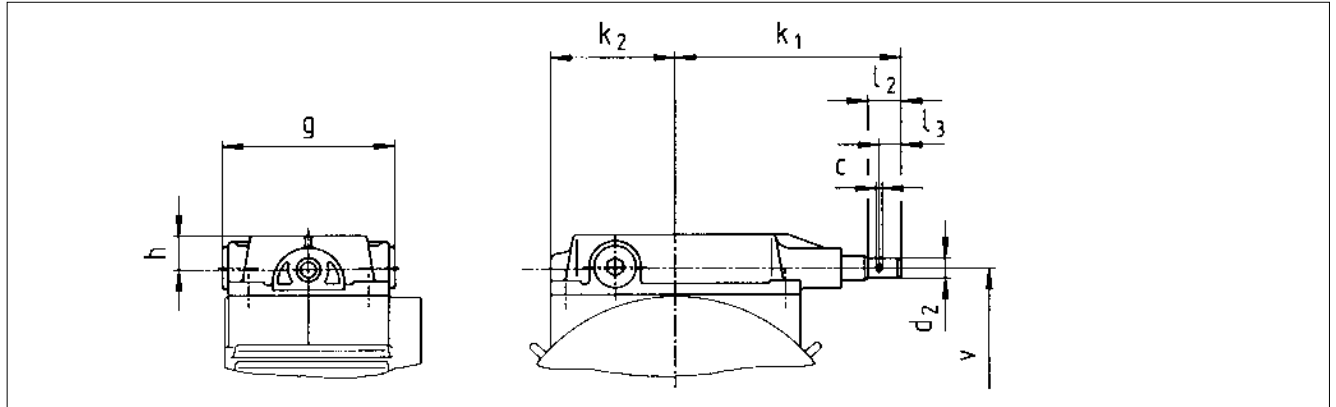

Size	$c$ $+0.1$	$d_2$ $h9$	$g$	$h$	$k_1$	$k_2$	$l_2$	$l_3$	$v$
02	3.2	8	64	14	74	43	12.5	7	83
03	3.2	8	64	14	74	43	12.5	7	86
04	3.2	10	86	17	114	63	16.5	11	103
05	3.2	10	86	17	114	63	16.5	11	123
06/07	3.2	10	86	17	114	63	16.5	11	149

#### Universal design suitable for hand wheel adjuster, bevel gear adjuster and electrical remote adjuster

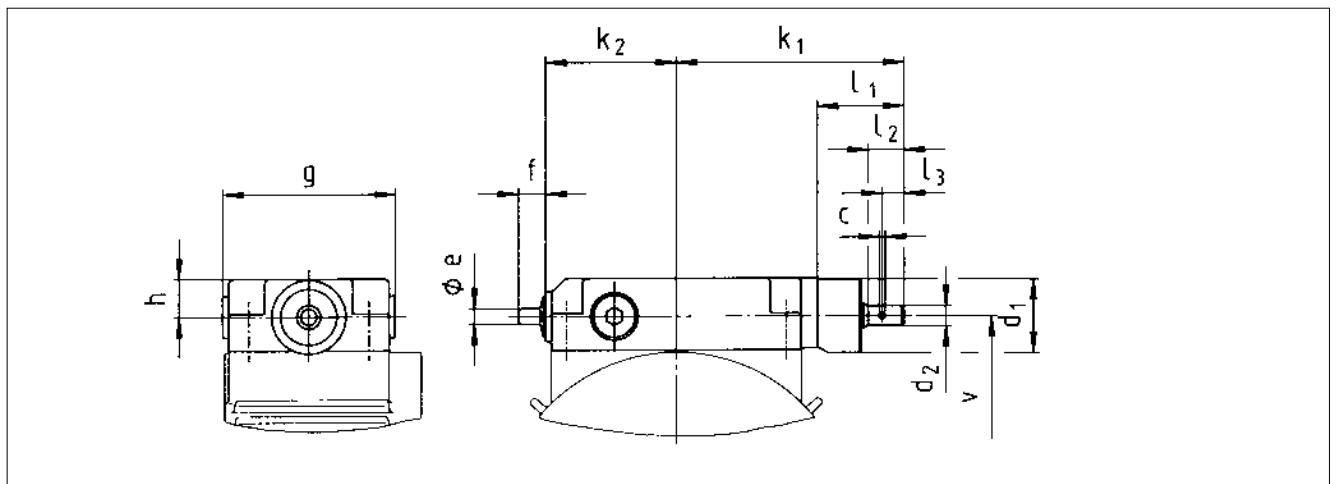

Size	$c$ $+0.1$	$d_1$ $h9$	$d_2$ $j7$	$e$	$f$	$g$	$h$	$k_1$	$k_2$	$l_1$	$l_2$	$l_3$	$v$
02	3.0	30	8	8	13	64	16	84	46	31	14	7	86
03	3.0	30	8	8	13	64	16	84	46	31	14	7	89
04	3.0	37	10	8	13	86	19	114	66	42	18	11	107
05	3.0	37	10	8	13	86	19	114	66	42	18	11	125
06/07	3.0	37	10	8	13	86	19	114	66	42	18	11	153
18/08*	4.0	52	15	8	13	106	26	161	98	55	21	14	190

\* for size 18/08 standard design  
Dimensions in [mm]

# DISCO-variable speed drive

## Drive selection

### Options – Speed-adjustment units

#### Bevel gear adjuster

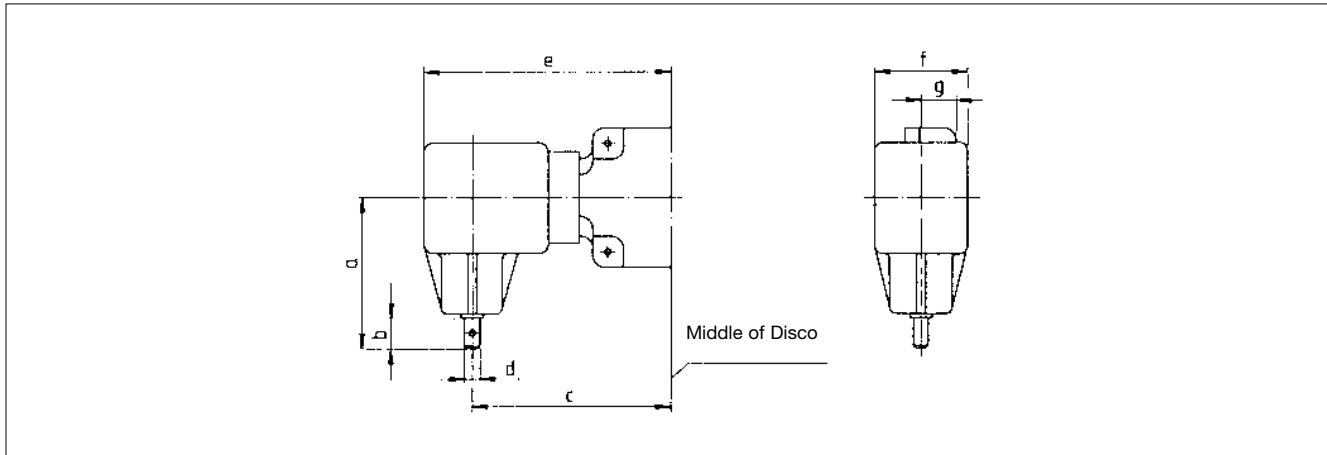

Size	a	b	c	d h8	e	f	g
02/03	75	22	94	8	116	46	16
04/05/06/07	93	18	127	10	157	56	19
18/08	107	21	173	15	203	73	26

Dimensions in [mm]

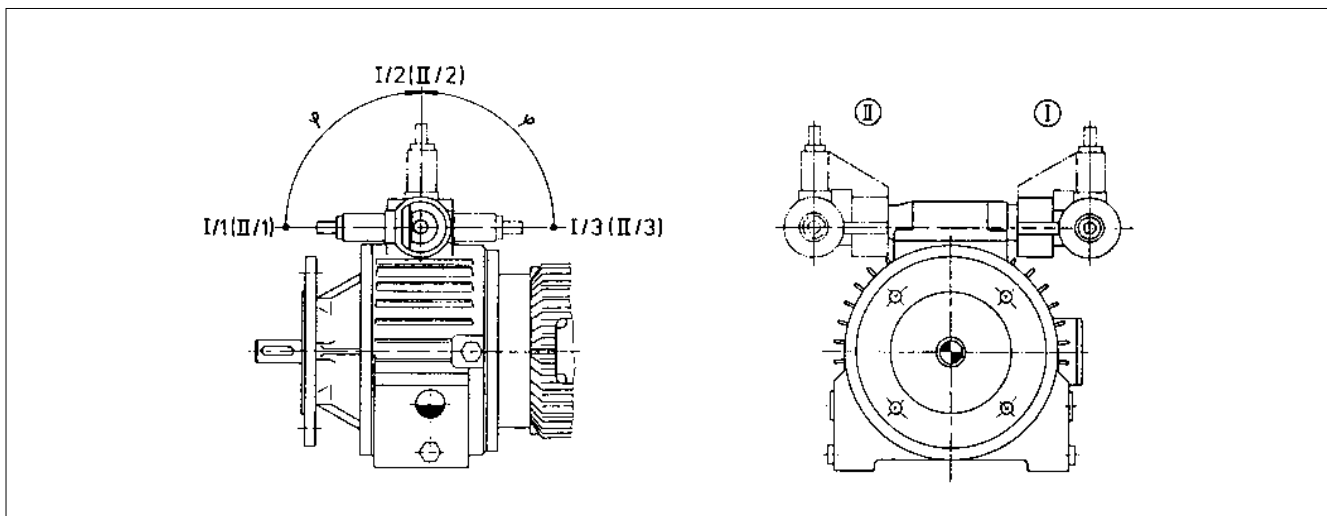

Size	Swivel range $\varphi$	
	Hand wheel	Hand wheel with position indicator
02/03/04	90°	0 – 45°
05/06/07	90°	0 – 45°
18/08	70°	20 – 45°

Dimensions in [mm]

### Options – Speed-adjustment units

#### Electrical remote adjuster

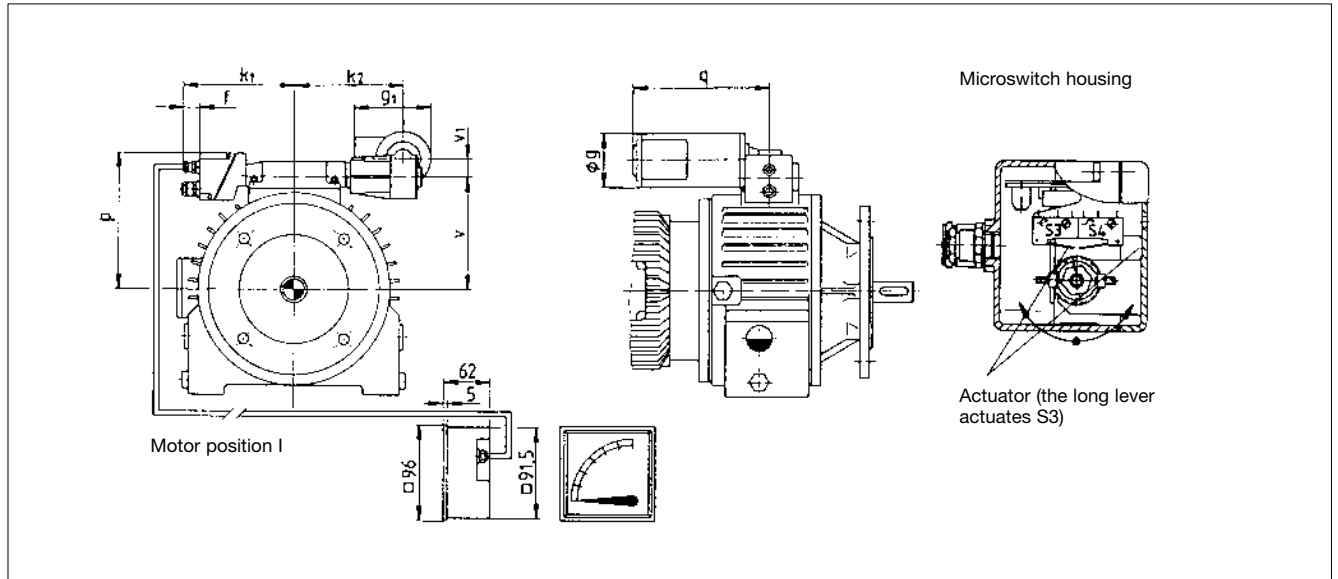

Terminal box pos. 2 of main motor is not possible

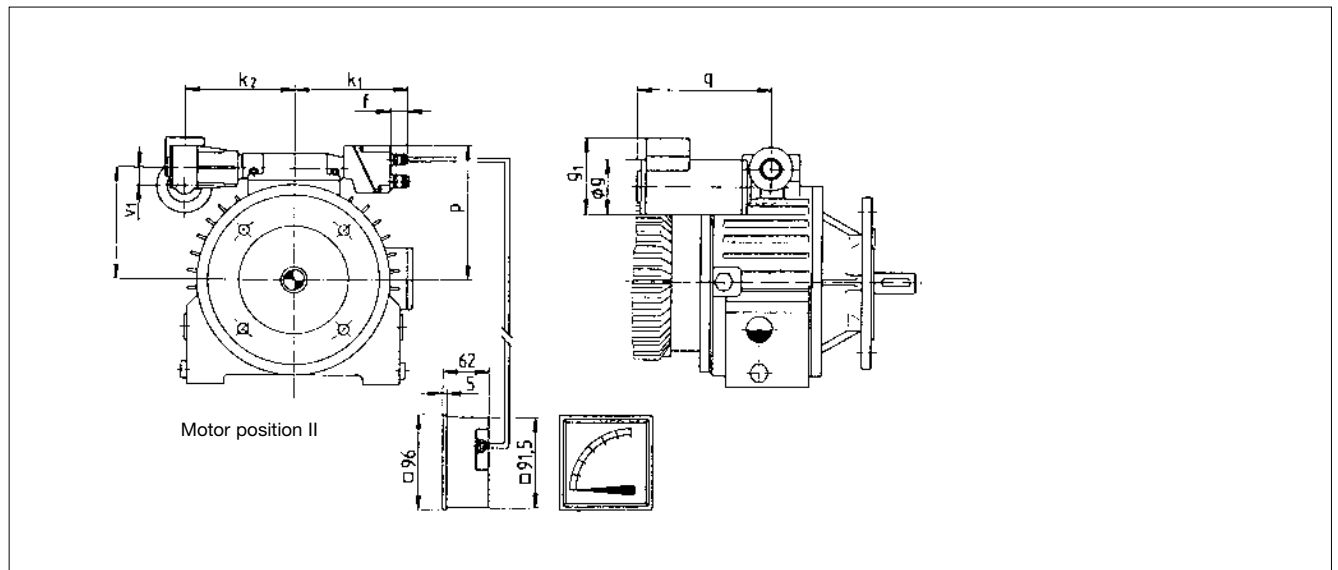

Terminal box pos. 3 of main motor is not possible

Size	f	g	g <sub>1</sub>	k <sub>1</sub>	k <sub>2</sub>	p	q	v	v <sub>1</sub>
02	19	65	123	137	119	118	170	86	25
03						121		89	
04	19	85	144	152	153	139	199	107	31
05						159		127	
06	19	85	144	152	153	185	199	153	31
07									
18/08	19	118	164	190	221 <sup>1)</sup>	222	221	190	40

<sup>1)</sup> with slipping clutch: 243 mm  
Dimensions in [mm]

# DISCO-variable speed drive

## Drive selection

### Options – Speed-measuring units

Design:

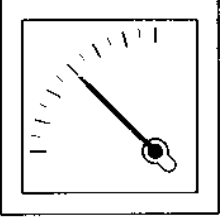
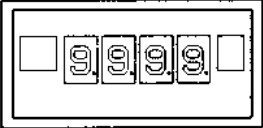
Name	Electrical remote control with potentiometer	Inductive speed measurement
Installation	– Potentiometer in the limit switch box of the electrical remote control	– inductive pulse encoder in the output cover
Supply voltage	– (Mains supply of the electrical remote control)	– (Generator)
Signal voltage	> 10 V (DC)	12 pulses/revolution > 1.0 V (AC)
Speed indicators – suitable for control-cabinet installation	Analog display – rear-side detector input – scaling in (V), adjustable  	
Digital display		– rear-side generator output/input – 4-digit display – adjustable display  



### Options – Speed-measuring units

#### Position indicator/Rev. direction indicator

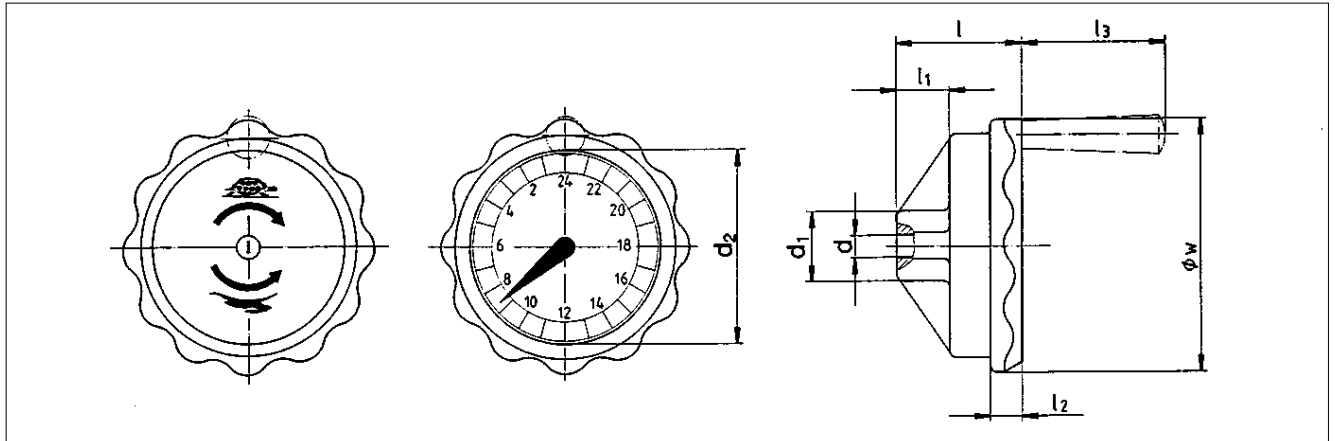

Size	Hand wheel with rev. direction indicator	Hand wheel with position indicator	$d$ $H_9$	$d_1$	$d_2$	$l$	$l_1$	$l_2$	$l_3$	$w$
02/03	HD 8	HA 8	08	20	52	43	15	10	–	070
04/05 06/07	HD 10	HA 10	10	30	85	55	23	14	–	105
18/08	HD 15	HA 15	15	25	85	55	23	15	80	160

#### Analog display type DQW 96 RS

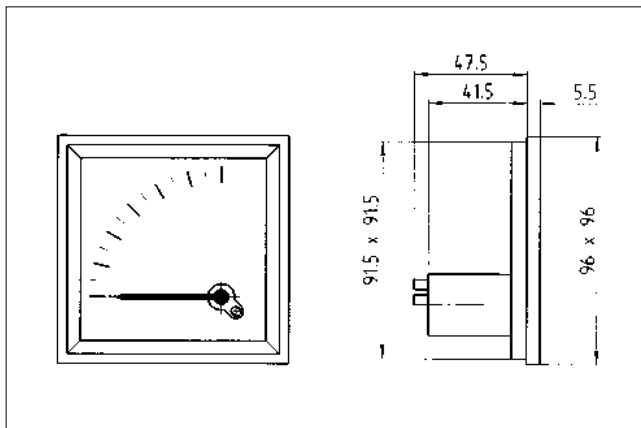

Dimensions in [mm]

#### Digital display type ELTA 2000 A

